

BAXI

ECO4S

en

High performance gas-fired wall-mounted boilers

Operating and installation instructions

Dear Customer,

Our company is confident our new product will meet all your requirements. Buying one of our products guarantees all your expectations: good performance combined with simple and rational use.

Please do not put this booklet away without reading it first: it contains useful information for the correct and efficient use of your product.

Our company declares that these products are in compliance with the essential requirements of the following Directives :

- Gas Directive **2009/142/EC**
- Efficiency Directive **92/42/EEC**
- Electromagnetic Compatibility Directive **2004/108/EC**
- Low Voltage Directive **2006/95/EC**

Our company, constantly striving to improve the products, reserves the right to modify the details given in this documentation at any time and without notice. These Instructions are only meant to provide consumers with use information and under no circumstance should they be construed as a contract with a third party.

The appliance can be used by children aged 8 or over and by people with reduced physical, sensory or mental faculties, or who do not have the required experience or knowledge, provided they are supervised or have received instructions on using the appliance safely and understanding its intrinsic hazards. Children must not play with the appliance. The cleaning and maintenance operations reserved to the user must not be performed by unsupervised children.

CONTENTS

INSTRUCTIONS FOR USERS

1. Instructions prior to installation	4
2. Instructions prior to commissioning	4
3. Commissioning the boiler	5
4. Adjusting ambient temperature and DHW temperature	6
5. Description of button  (Summer - Winter - Heating only - Off)	6
6. Filling the system	7
7. Turning off the boiler	7
8. Gas conversion	7
9. Prolonged shutdown. Frost protection (central heating circuit)	8
10. Troubleshooting	8
11. Routine maintenance instructions	8

INSTRUCTIONS FOR FITTERS

12. General information	9
13. Instructions prior to installation	9
14. Installing the boiler	10
15. Dimensions of boiler	11
16. Installation of flue and air ducts	12
17. Connecting the mains supply	16
18. Connecting the ambient thermostat	16
19. Gas conversion methods	17
20. Visualisation of electronic board parameters on boiler display ("info" function)	19
21. Parameters setting	20
22. Adjustment and safety devices	21
23. Positioning the ignition and flame-sensor electrode	22
24. Checking combustion parameters	22
25. Output/pump head performance	22
26. Connecting the external probe	23
27. Connection of an external storage boiler	23
28. Notes for installations with separate outlets	24
29. Annual servicing	25
30. Cleaning the filters	26
31. Removing scale from the DHW circuit	26
32. Dismounting the water-water heat exchanger	26
33. Circuit diagram	27-29
34. Illustrated wiring diagram	30-32
35. Technical data	33

1. INSTRUCTIONS PRIOR TO INSTALLATION

This boiler has been designed to heat water to a temperature lower than boiling point at atmospheric pressure. It must be connected to a central heating system and to a domestic hot water supply system according to its performance and power output.

Before having the boiler installed by a qualified service engineer, make sure the following operations are performed:

- a) Make sure that the boiler is adjusted to use the type of gas delivered by the gas supply. To do this, check the markings on the packaging and the rating plate on the appliance.
- b) Make sure that the flue terminal draft is appropriate, that the terminal is not obstructed and that no exhaust gases from other appliances are expelled through the same flue duct, unless the latter has been specially designed to collect exhaust gas from more than one appliance, in compliance with current laws and regulations.
- c) Make sure that, if the boiler is connected to existing flue ducts, these have been thoroughly cleaned as residual products of combustion may detach from the walls during operation and obstruct the flow of fumes.
- d) To ensure correct operation and maintain the warranty, observe the following precautions:

1. DHW circuit:

- 1.1. If the water is harder than 20 °F (1 °F = 10 mg calcium carbonate per litre of water), install a polyphosphate dispenser or an equivalent treatment system, compliant with current regulations.
- 1.2. Thoroughly flush the system after installation of the appliance and before use.
- 1.3. The materials used for the domestic hot water circuit of the product comply with Directive 98/83/EC.

2. Heating circuit

2.1. new system

Before proceeding with installation of the boiler, the system must be cleaned and flushed to eliminate residual thread-cutting swarf, solder and any solvents, using suitable proprietary products. To avoid damaging metal, plastic and rubber parts, only use neutral cleaners, i.e. non-acid and non-alkaline. Recommended cleaning products are: SENTINEL X300 or X400 and FERNOX Regenerator for heating circuits. Use these products in strict compliance with the manufacturers' instructions.

2.2. existing plant:

Before installing the boiler, drain the system and clean it to remove sludge and contaminants, using suitable proprietary products as described in section 2.1. To avoid damaging metal, plastic and rubber parts, use only neutral cleaners, i.e. non-acid and non-alkaline such as SENTINEL X100 and FERNOX Protector for heating circuits. Use these products in strict compliance with the manufacturers' instructions. Remember that the presence of foreign bodies in the heating system can adversely affect boiler operation (e.g. overheating and excessive noise of the heat exchanger).

Failure to observe the above will render the guarantee null and void.

2. INSTRUCTIONS PRIOR TO COMMISSIONING

Initial lighting of the boiler must be carried out by an authorised Service Engineer who must first ensure that:

- a) the rated data correspond to the supply (electricity, water and gas) data;
- b) the installation complies with current laws and regulations;
- c) the appliance is correctly connected to the power supply and earthed.

The names of the authorised Service Centres are indicated in the attached sheet.

Failure to observe the above will render the guarantee null and void.

Prior to commissioning, remove the protective plastic coating from the boiler. Do not use any tools or abrasive detergents to do this as you may damage the painted surfaces.

The instructions shall state the substance of the following:

This appliance is not intended for use by persons (including children) with reduced physical, sensory or mental capabilities, or lack of experience and knowledge, unless they have been given supervision or instruction concerning use of the appliance by a person responsible for their safety.

Children should be supervised to ensure that they do not play with the appliance.

3. COMMISSIONING THE BOILER

To light the boiler correctly, proceed as follows:

- 1) power the boiler
- 2) open the gas tap;
- 3) press the button (⏻) and switch the boiler to Summer (☀️), Winter (❄️) or heating only (🔥);
- 4) press the heating circuit (🔥) and domestic hot water circuit (🚰) temperature adjustment buttons (+/-) in order to ignite the main burner.

When the boiler is lit, the symbol (🔥) will appear on the display.

In the Summer position (☀️) the main burner will only ignite if a DHW tap is turned on.

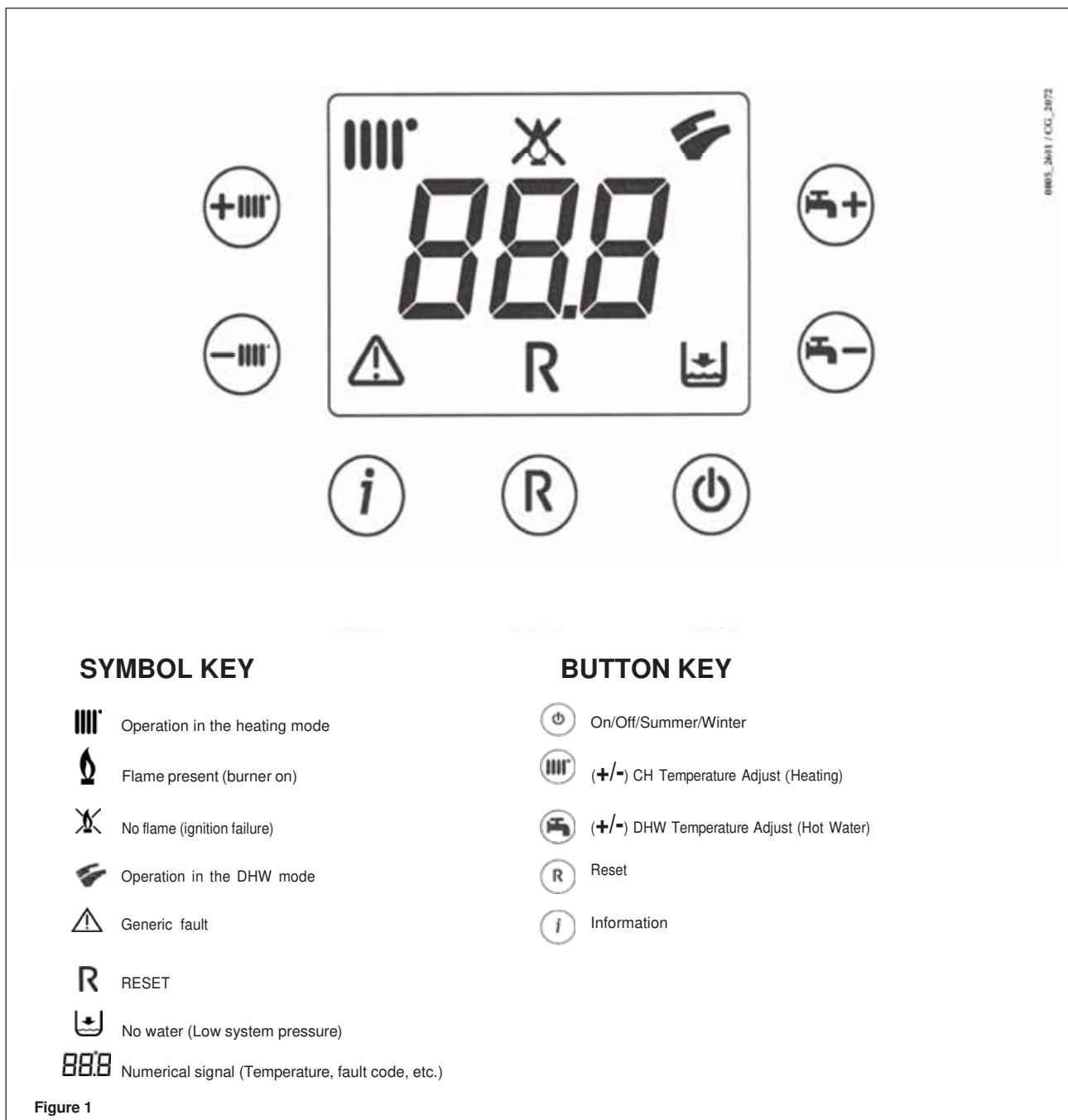

Warning:

During initial ignition, the burner may not ignite (causing the boiler to shut down) until any air in the gas pipes is vented. In this case, repeat the ignition procedure until gas reaches the burner. Press button (R), for at least 2 seconds.



4. ADJUSTING AMBIENT TEMPERATURE AND DHW TEMPERATURE

The system must be equipped with an ambient thermostat for controlling the room temperature.

Adjust the ambient temperature () and the DHW temperature () by pressing the respective +/- buttons (figure 1). The ignition of the burner is shown on the display with the symbol () as described in section 3.1.

HEATING

While the boiler is operating in heating mode, the display (figure 1) shows the flashing symbol () and the heating delivery temperature (°C).

DOMESTIC HOT WATER



While the boiler is operating in DHW mode, the display (figure 1) shows the flashing symbol () and the DHW output temperature (°C).

5. DESCRIPTION OF BUTTON (Summer - Winter - Heating Only - Off)



Press this button to set the following boiler operating modes:

- SUMMER
- WINTER
- HEATING ONLY
- OFF

In **SUMMER** mode, the display shows (). The boiler satisfies requests for DHW only while central heating is NOT enabled (ambient frost protection function active).

In **WINTER** mode, the display shows () and (). The boiler satisfies requests for both DHW and central heating (ambient frost protection function active).

In **HEATING ONLY** mode, the display shows (). The boiler satisfies requests for central heating only (ambient frost protection function active).

In **OFF** mode, the display shows neither of the above two symbols () (). In this mode only the ambient frost protection function is enabled, any other request for DHW or heating is not satisfied.

6. FILLING THE SYSTEM

WARNING

Disconnect the boiler from the mains power supply using the two-pole switch.

IMPORTANT: Regularly check that the pressure displayed on the pressure gauge is 0.7 - 1.5 bar, with the boiler cold. In case of overpressure, open the boiler drain tap. In case of insufficient temperature, open the boiler filling tap (figure 3). Open the tap very slowly in order to vent the air.

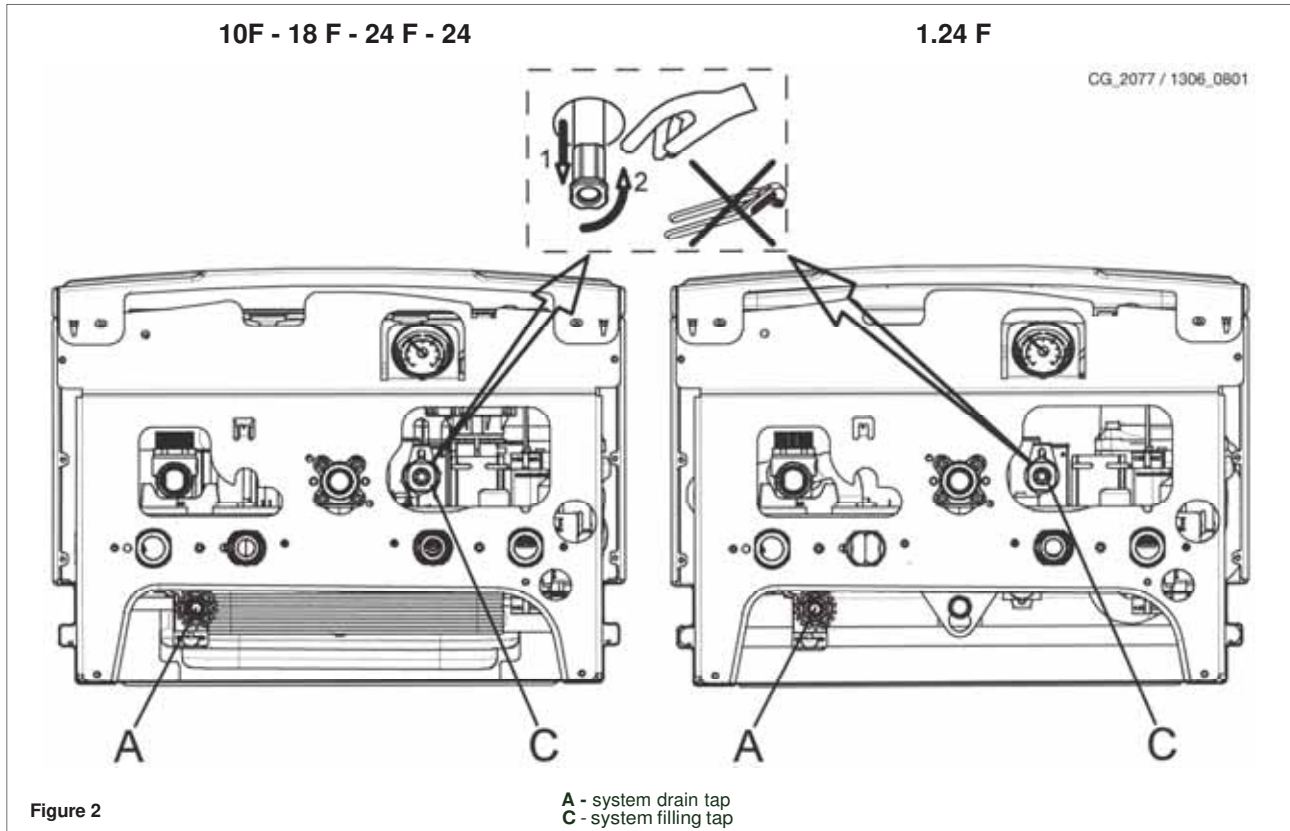

The boiler is fitted with a hydraulic pressure gauge which prevents the boiler from working if there is no water.

N.B.: In case pressure drops occur frequently, have the boiler checked by an authorised Service Engineer.

7. TURNING OFF THE BOILER

To switch off the boiler, disconnect the electric power supply.

In OFF mode (section 5) the boiler remains off (the display indicates OFF) but the electrical circuits remain live and the frost protection device is enabled (section 9).

8. GAS CONVERSION

The boilers can operate both on natural gas and **LPG**.

All gas conversions must be made by an authorised Service Engineer.

9. PROLONGED SHUTDOWN. FROST PROTECTION

Do not drain the whole system as filling up with water again causes unnecessary and harmful scale to build up inside the boiler and the heating elements. If the boiler is not used during winter and is therefore exposed to the danger of frost, add some specific anti-freeze to the water in the system (e.g.: propylene glycol coupled with corrosion and scale inhibitors). The electronic boiler management system includes a "frost protection" function for the heating system which, when delivery temperature falls below 5°C, operates the burner until a delivery temperature of 30°C is reached.

The frost protection function is enabled if:

- * the boiler is electrically powered;
- * the gas tap is open;
- * the system is at the correct pressure;
- * the boiler is not blocked.

10. TROUBLESHOOTING

Faults are shown on the display with an error code (e.g.: E 01):

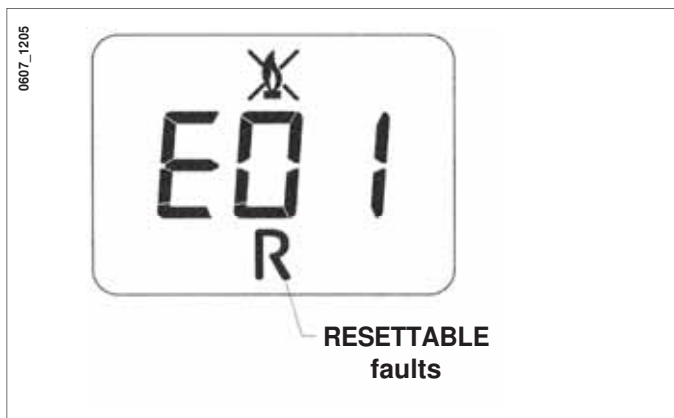

To RESET the boiler, press and hold down "R" for at least 2 seconds. If this fault persists, call the Authorised Service Centre.

N.B.: 5 reset attempts can be performed after which the boiler shuts down. To reset again, switch off the boiler for a few seconds.

CODE DISPLAYED	FAULT	CORRECTIVE ACTION
E01	Failed ignition shutdown	Press and hold down "R". for at least 2 seconds. If this fault persists, call the Authorised Service Centre.
E02	Safety thermostat tripped	Press and hold down "R". for at least 2 seconds. If this fault persists, call the Authorised Service Centre.
E03	Flue thermostat/ flue pressure switch tripped	Call the Authorised Service Centre.
E04	Shutdown after 6 consecutive flame losses	Press and hold down "R". for at least 2 seconds. If this fault persists, call the Authorised Service Centre.
E05	Delivery probe failure	Call the Authorised Service Centre.
E06	DHW sensor fault	Call the Authorised Service Centre.
E10	Hydraulic pressure switch block	Check that the pressure in the system is correct; See section 6. If this fault persists, call the Authorised Service Centre.
E25/E26	Probable blocked pump safety trip.	Call the Authorised Service Centre.
E32	Limescale alarm	Call the Authorised Service Centre.
E35	Parasite flame (flamer error)	Press and hold down "R". for at least 2 seconds. If this fault persists, call the Authorised Service Centre.
E96	Switching off due to reductions in the power supply	RESET is automatic. If this fault persists, call the Authorised Service Centre.

N.B.: in case of a fault, the display backlighting flashes together with the error code.

11. ROUTINE MAINTENANCE INSTRUCTIONS

To keep the boiler efficient and safe, have it checked by the authorised Service Centre at the end of every operating period. Careful servicing ensures economical operation of the system.

Do not clean the outer casing of the appliance with abrasive, aggressive and/or easily flammable cleaners (e.g.: petrol, alcohol, and so on). Always switch off the appliance before cleaning it (see section 7 "Switching off the boiler").

12. GENERAL INFORMATION

The following notes and instructions are addressed to fitters to allow them to carry out trouble-free installation. Instructions for lighting and using the boiler are contained in the 'Instructions for Users' section. Moreover, the installation technician must be qualified to install heating appliances.

Additionally, bear in mind the following:

- This boiler can be connected to any type of double- or single-pipe convector plate, radiator or thermoconvector. Design the system sections as usual, though, bearing in mind the available flow-head at the plate, as shown in section 25.
- Do not leave any packaging (plastic bags, polystyrene, etc.) within the reach of children as they are a potential source of danger.
- Initial lighting of the boiler must be carried out by an authorised Service Engineer, as indicated on the attached sheet. Failure to observe the above will render the guarantee null and void.

ADDITIONAL PUMP WARNING

If an additional pump is used on the heating system, position it on the boiler return circuit. This will allow the correct operation of the water pressure switch.

WARNING

If the instantaneous (mixed) boiler is connected to a system with solar panels, the maximum temperature of the domestic hot water entering the boiler must not exceed **60°C**.

13. INSTRUCTIONS PRIOR TO INSTALLATION

This boiler has been designed to heat water to a temperature lower than boiling point at atmospheric pressure. It must be connected to a central heating system and to a domestic hot water supply system according to its performance and power output.

Do the following before connecting the boiler:

- a) Make sure that the boiler is adjusted to use the type of gas delivered by the gas supply. To do this, check the markings on the packaging and the rating plate on the appliance.
- b) Make sure that the flue terminal draft is appropriate, that the terminal is not obstructed and that no exhaust gases from other appliances are expelled through the same flue duct, unless the latter has been specially designed to collect exhaust gas from more than one appliance, in compliance with current laws and regulations.
- c) Make sure that, if the boiler is connected to existing flue ducts, these have been thoroughly cleaned as residual products of combustion may detach from the walls during operation and obstruct the flow of fumes.

To ensure correct operation and maintain the warranty, observe the following precautions:

1. DHW circuit:

- 1.1. If the water is harder than 20 °F (1 °F = 10 mg calcium carbonate per litre of water), install a polyphosphate dispenser or an equivalent treatment system, compliant with current regulations.
- 1.2. Thoroughly flush the system after installation of the appliance and before use.
- 1.3. The materials used for the domestic hot water circuit of the product comply with Directive 98/83/EC.

2. Heating circuit

2.1. new system

Before proceeding with installation of the boiler, the system must be cleaned and flushed to eliminate residual thread-cutting swarf, solder and any solvents, using suitable proprietary products. To avoid damaging metal, plastic and rubber parts, only use neutral cleaners, i.e. non-acid and non-alkaline. Recommended cleaning products are: SENTINEL X300 or X400 and FERNOX Regenerator for heating circuits. Use these products in strict compliance with the manufacturers' instructions.

2.2. existing plant:

Before installing the boiler, drain the system and clean it to remove sludge and contaminants, using suitable proprietary products as described in section 2.1. To avoid damaging metal, plastic and rubber parts, use only neutral cleaners, i.e. non-acid and non-alkaline such as SENTINEL X100 and FERNOX Protector for heating circuits. Use these products in strict compliance with the manufacturers' instructions. Remember that the presence of foreign bodies in the heating system can adversely affect boiler operation (e.g. overheating and excessive noise of the heat exchanger).

Failure to observe the above will render the guarantee null and void.

14. INSTALLING THE BOILER

After deciding the exact location of the boiler, fix the template to the wall.

Connect the system to the gas and water inlets present on the lower bar of the template. Fit two G3/4 taps (delivery and return) on the central heating circuit; these taps make it possible to carry out important operations on the system without draining it completely. If you are either installing the boiler on an existing system or replacing one, as well as the above, fit a settling tank under the boiler on the system return line in order to collect any deposits and scale circulating in the system after flushing. After fixing the boiler to the template, connect the flue and air ducts, supplied as accessories, as described in the following sections.

If the model **24** natural draught boiler is installed, connected it to the flue with a metal pipe resistant to normal mechanical stress, heat, products of combustion and relative condensate.

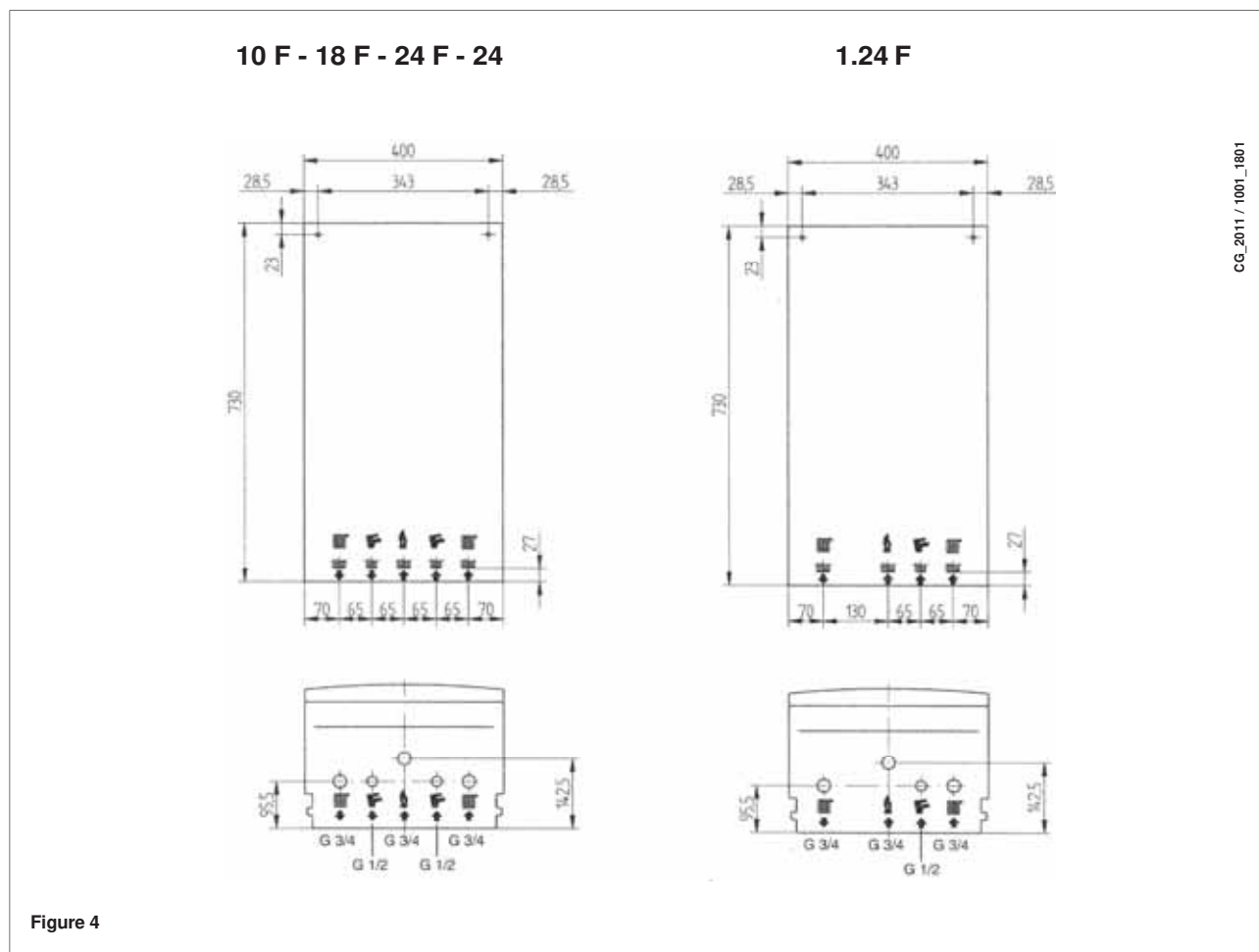







Figure 4

WARNING

Carefully tighten the water connections to the nipples of the boiler (maximum tightening torque 30 Nm).

	G"3/4 HEATING DELIVERY
	G"3/4 HEATING RETURN
	G"1/2 DOMESTIC HOT WATER OUTLET
	G"1/2 DOMESTIC COLD WATER INLET
	G"3/4 GAS INLET TO BOILER

15. DIMENSIONS OF BOILER

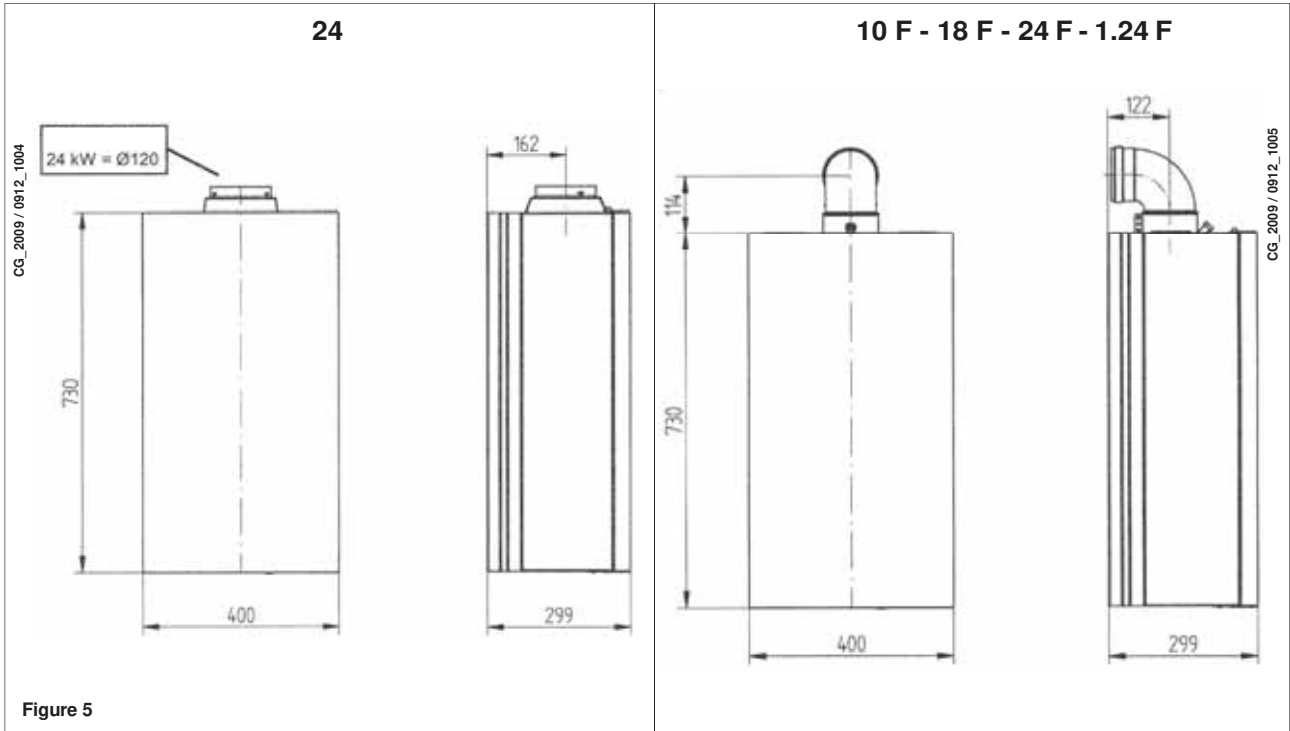

16. INSTALLING THE FLUE AND AIR DUCTS

Model 24 F - 1.24 F - 10 F - 18 F

The boiler is easy and flexible to install thanks to the extensive range of available accessories, as described below. The boiler has been designed for connection to a vertical or horizontal coaxial flue-air duct. A splitting kit is also available if separate ducts are required.

Only accessories supplied by the manufacturer must be used for installation!

WARNING : To guarantee more operating insurance it is necessary to assure the flue pipes to the wall using the apposite clamps.

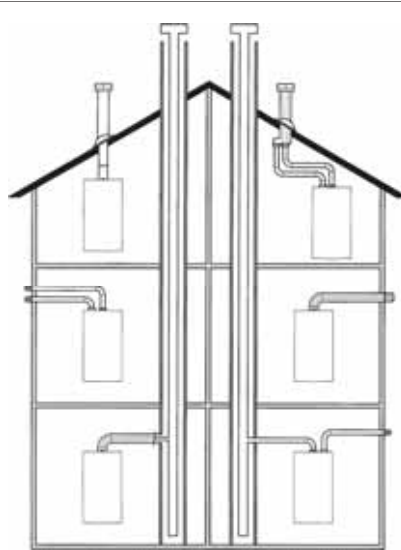

Figure 6

... COAXIAL FLUE-AIR DUCT (CONCENTRIC)

This type of duct is used to discharge exhaust fumes and draw combustion air both outside the building and if a LAS flue is fitted.

The 90° coaxial bend allows the boiler to be connected to a flue-air duct in any direction as it can be rotated by 360°. It can also be used as a supplementary bend combined with a coaxial duct or a 45° bend.

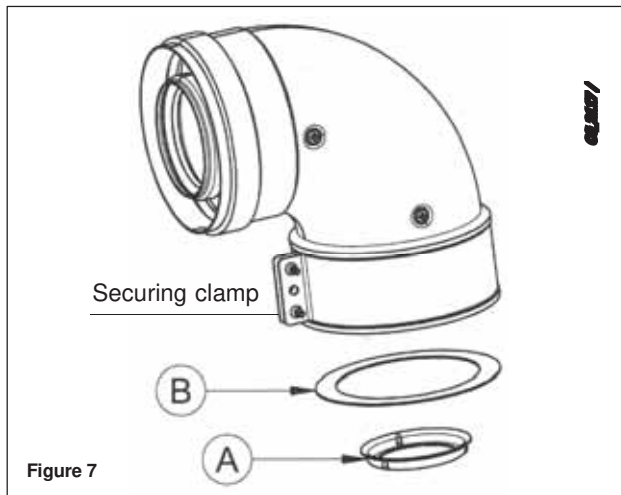

Figure 7

If fumes are discharged outside the building, the flue-air duct must protrude at least 18 mm from the wall to allow an aluminium weathering surround to be fitted and sealed to avoid water infiltrations. Make sure there is a minimum upward slope towards the outside of 1 cm per metre of duct.

- a 90° bend reduces total duct length by 1 metre.
- a 45° bend reduces total duct length by 0.5 metres.

The first 90° bend is not included when calculating the maximum available length.

Boiler model	Length (m)	Air suction RESTRICTOR B	Flue RESTRICTOR A
24 F - 10 F	0 ÷ 1	No	Yes
1.24 F - 18 F	1 ÷ 5		No

16.1 HORIZONTAL FLUE INSTALLATION OPTIONS

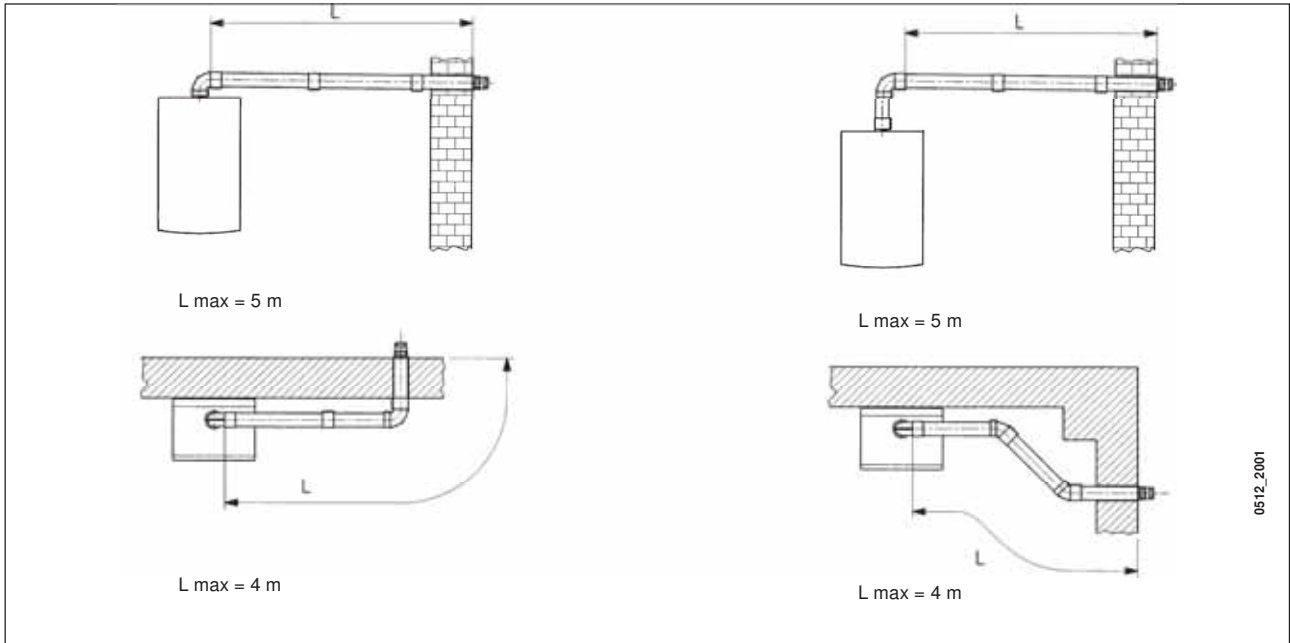

16.2 LAS FLUE DUCT INSTALLATION OPTIONS

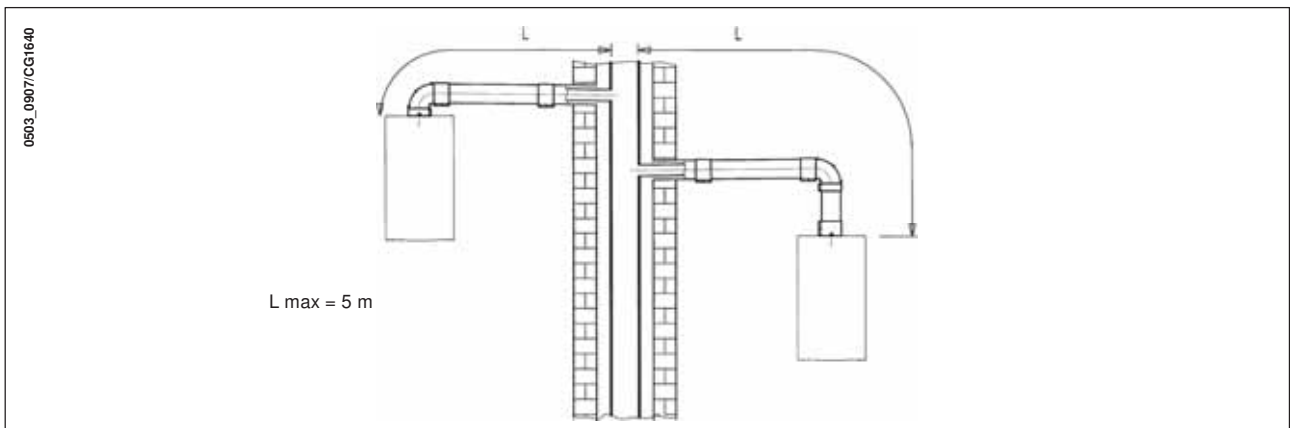

16.3 VERTICAL FLUE INSTALLATION OPTIONS

This type of installation can be carried out on either a flat or a pitched roof by fitting a flue terminal and a special weathering surround with sleeve (both available on request).

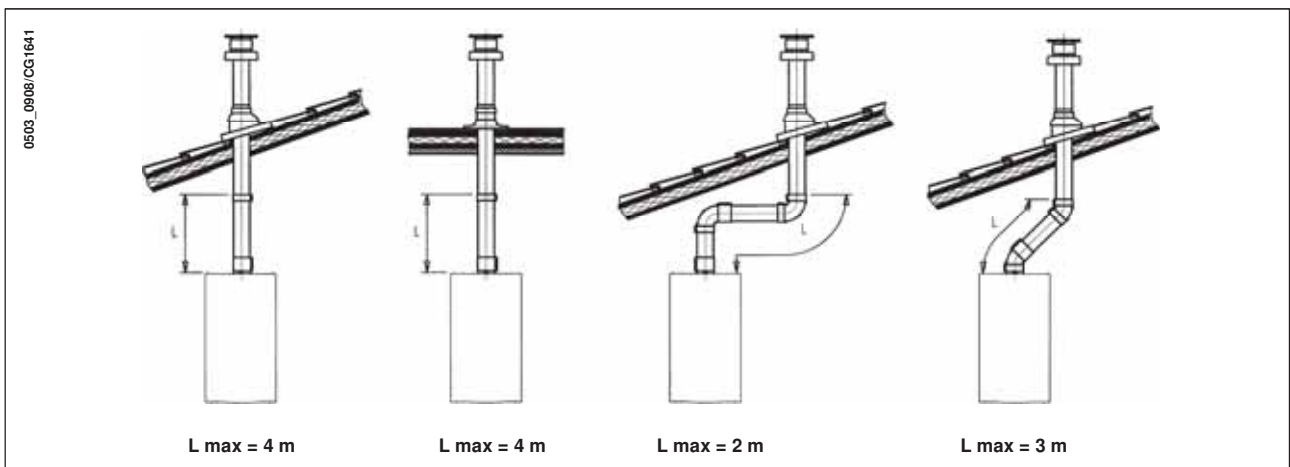

For detailed installation instructions, consult the technical data provided with the accessories.

... SEPARATE FLUE AND AIR DUCTS

This type of installation makes it possible to discharge exhaust fumes both outside the building and into single flue ducts. Comburent air can be drawn in at a different location from that of the flue terminal. The splitting kit comprises a flue duct adaptor (100/80) and an air duct adaptor. For the air duct adaptor, fit the screws and seals previously removed from the cap.

BOILER MODEL	(L1+L2)	Position of air regulator	Flue Restrictor A	CO % (*)	
				G20	G31
24 F - 10 F 1.24 F - 18 F	0 ÷ 4	A	NO	6,4	7,2
	4 ÷ 14	B			
	14 ÷ 23	C			

(*) (for 10 F and 18 F models, the gas boiler has to operate in DHW)

The first 90° bend is not included when calculating the maximum available length.

The 90° bend allows the boiler to be connected to a flue-air duct in any direction as it can be rotated by 360°. It can also be used as a supplementary bend combined with a duct or a 45° bend.

- A 90° bend reduces total duct length by 0.5 metres.
- A 45° bend reduces total duct length by 0.25 metres.

WARNING

The boiler inlet and outlet ducts (C52) must comply with the following maximum lengths:

- inlet duct: Lmax= 8m
- outlet duct: Lmax= 15m

Adjusting the air regulator for separate flues

This regulator must be adjusted to optimise combustion efficiency and parameters. After turning the air intake connector, which can be mounted both to the right and the left of the exhaust flue duct, suitably adjust the excess air according to the total length of the combustion exhaust and inlet flue ducts. Turn this regulator counter-clockwise to decrease the excess of comburent air and vice-versa to increase it. To fine tune, use a combustion product analyser to measure the amount of CO₂ in the fumes at maximum heat capacity (for 10 F and 18 F models, the gas boiler has to operate in DHW) and, if a lower value is measured, gradually adjust the air regulator until the amount of CO₂ indicated in the following table is measured. To mount this device correctly, consult the relative instructions.

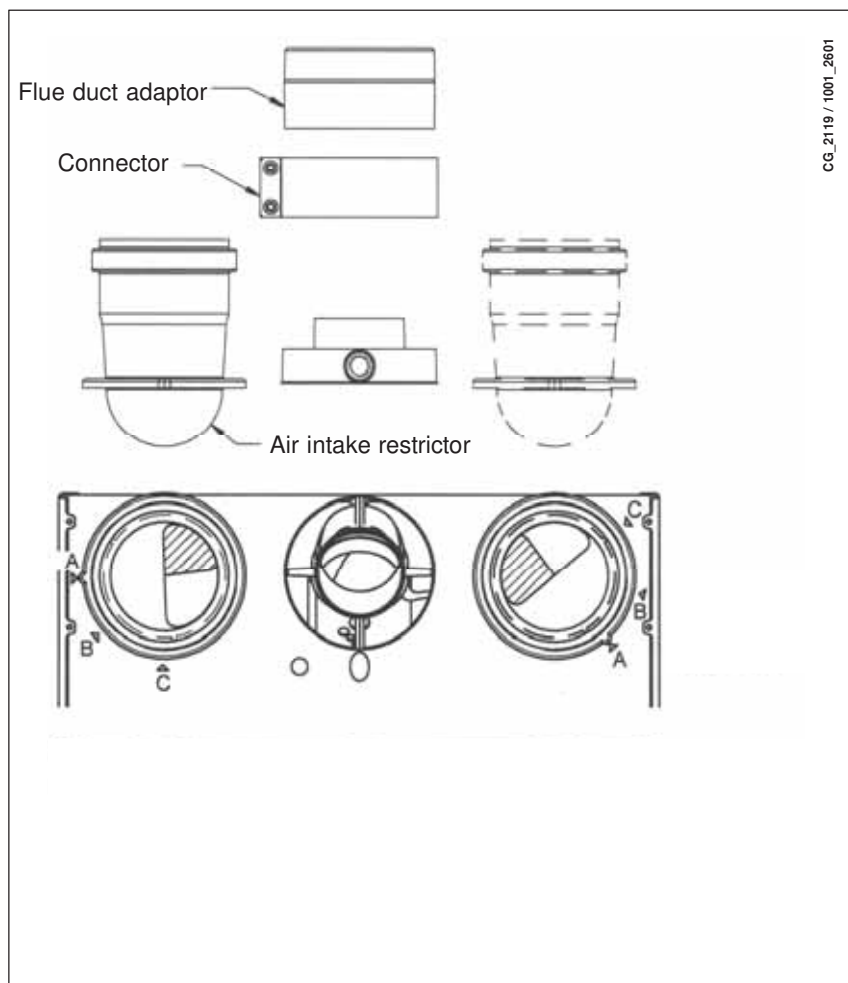
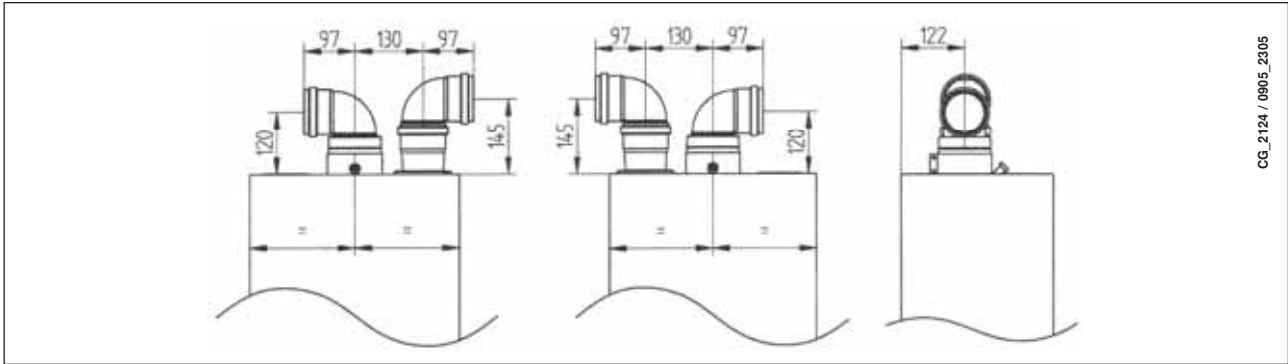

Figure 8

16.4 DIMENSIONS OF SEPARATE OUTLETS



CG_2124 / 0905_2305

16.5 SEPARATE HORIZONTAL FLUE TERMINALS INSTALLATION OPTIONS

IMPORTANT - Make sure there is a minimum downward slope towards the outside of 1 cm per metre of duct length. If the condensate collection kit is installed, the discharge duct must slope down towards the boiler.

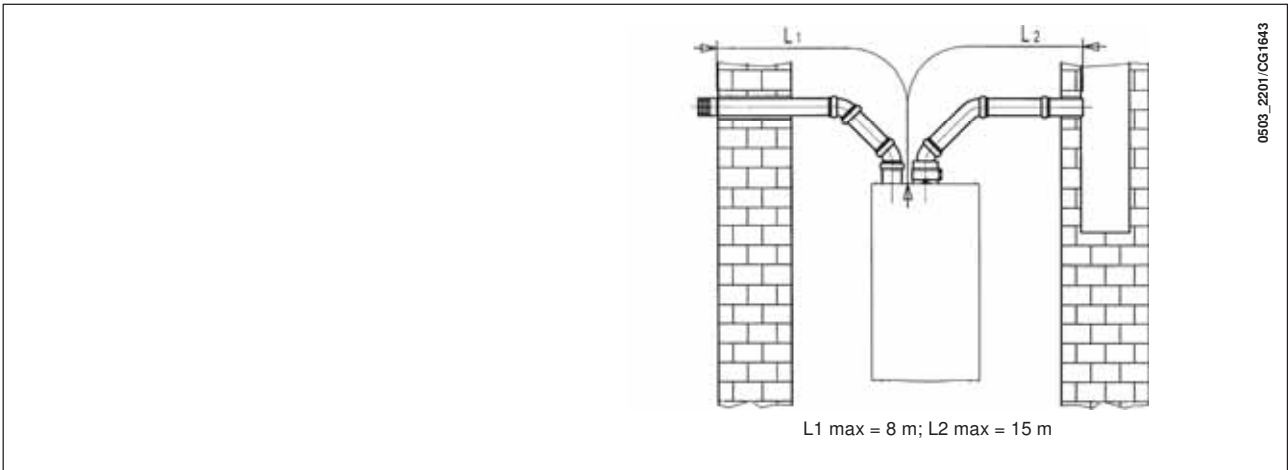

0503_2201/CG1643

N.B.: For the C52 type, do not fit the flue and air duct terminals on opposite walls of the building.

If the discharge duct is longer than 6 metres, install the condensate collection kit, supplied as an accessory, near the boiler.

16.6 SEPARATE VERTICAL FLUE INSTALLATION OPTIONS

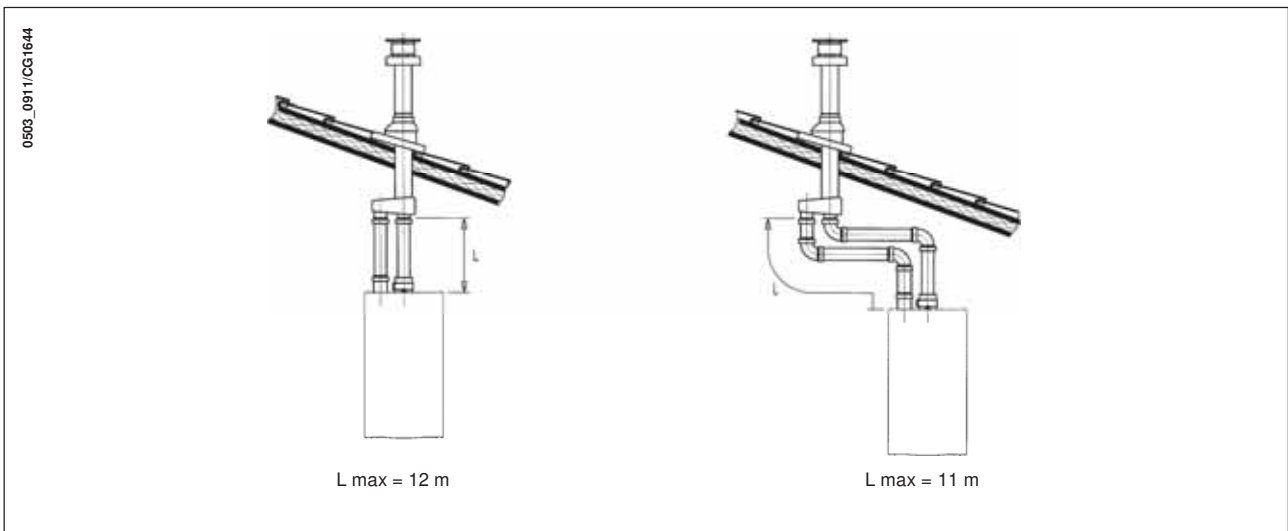

0503_0911/CG1644

IMPORTANT: if fitting a single flue duct, make sure it is adequately insulated (e.g.: with glass wool) wherever the duct passes through building walls. For detailed installation instructions, consult the technical data provided with the accessories.

17. ELECTRICAL CONNECTIONS

This machine is only electrically safe if it is correctly connected to an efficient earth system in compliance with current safety regulations.

Connect the boiler to a 230V single-phase earthed power supply using the supplied three-pin cable, observing correct LIVE-NEUTRAL polarity.

Use a double-pole switch with a contact separation of at least 3 mm.

When replacing the power supply cable, fit a harmonised HAR H05 VV-F' 3x0.75mm² cable with a maximum diameter of 8 mm.

...Access to the power supply terminal block

- disconnect the boiler from the mains power supply using the two-pole switch;
- remove the two screws fixing the control panel to the boiler;
- rotate the control panel;
- remove the cover and access the wiring area (figure 9).

The 2A fast-blowing fuse is incorporated in the power supply terminal block (to check and/or replace the fuse, pull out the black fuse carrier).

IMPORTANT: respect polarity **L** (LIVE) - **N** (NEUTRAL).

(L) = **Live** (brown)

(N) = **Neutral** (blue)

⊕ = **Earth** (yellow-green)

(1) (2) = **Contact for ambient thermostat**

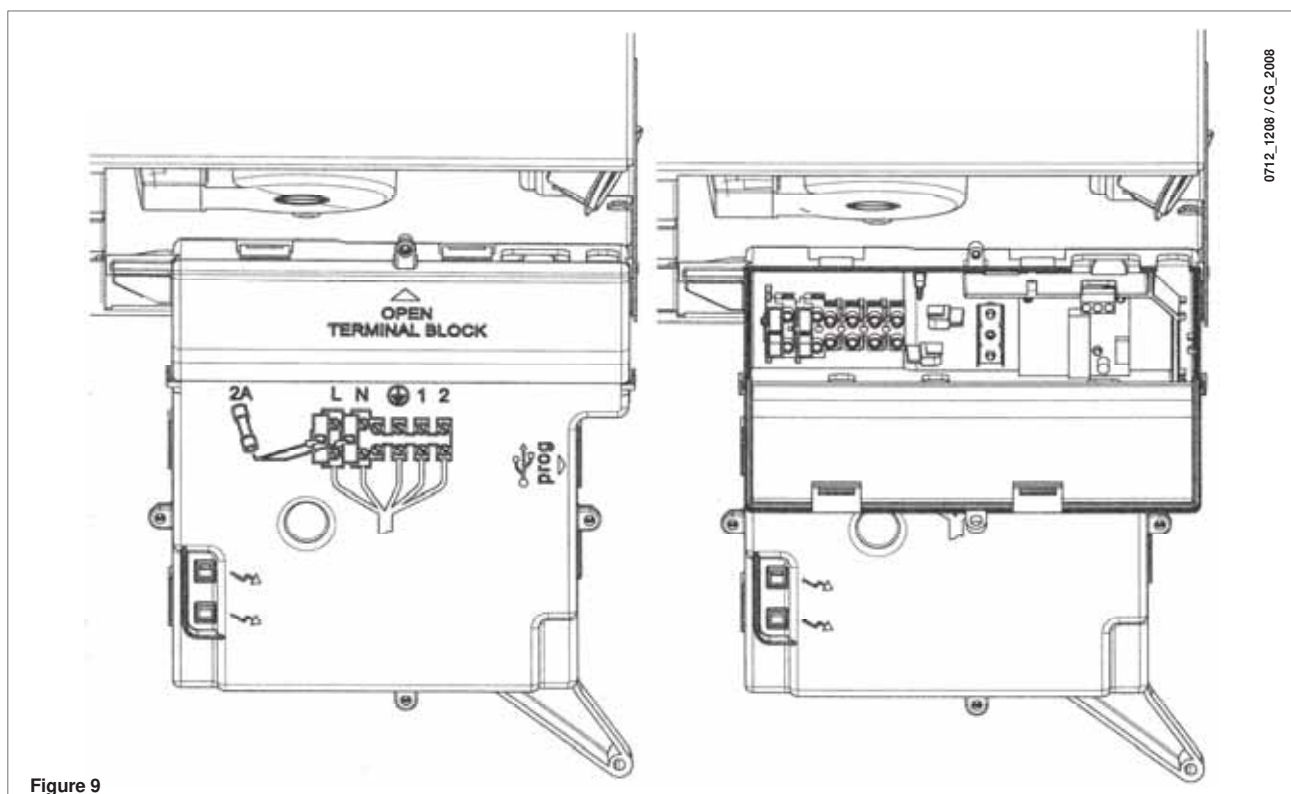

18. CONNECTING THE ROOM THERMOSTAT

- access the power supply terminal block (figure 9) as described in the previous section;
- remove the jumper on terminals (1) and (2);
- thread the two-wire cable through the grommet and connect it to these two terminals.

19. GAS CONVERSION

The authorised Technical Assistance Service can convert this boiler to natural gas (**G20**) or liquid gas (**G31**).

Carry out the following operations:

- A) replace the main burner nozzles;
- B) parameterise the electronic board;
- C) new max. and min. calibration of the pressure regulator.

A) Replace the burner injectors

- carefully pull the main burner off its seat;
- replace the main burner injectors making sure to fully tighten them to prevent gas leaks. Injector diameters are specified in table 2.

B) Parameterise the electronic board

- set parameter **F02** according to the gas used, as described in section 21;
- only for model 10 F - 18 F set parameter F08 = 100.

C) Calibrate the pressure regulator

- connect the positive pressure test point of a differential pressure gauge (possibly water-operated) to the gas valve pressure test point (**Pb**) (Figure 10). Only for models with sealed chambers, connect the negative pressure test point of the pressure gauge to a "T" fitting in order to join the boiler adjustment outlet, the gas valve adjustment outlet (**Pc**) and the pressure gauge. (The same measurement can be made by connecting the pressure gauge to the pressure test point (**Pb**) after removing the front panel of the sealed chamber). Measuring burner pressure using methods other than those described could lead to incorrect results as the low pressure created by the fan in the sealed chamber would not be taken into account.

C1) Adjustment to nominal heat output:

- open the gas tap and switch the boiler to the Winter mode;
- open a hot water tap that can provide a flow rate of at least **10 litres a minute** or make sure there is maximum heat demand;
- remove the modulator cover;
- adjust the brass screw (a) until the pressure values shown in table 1 are obtained;
- make sure that the dynamic inlet pressure of the boiler, measured at the gas valve pressure test point (Pa) (Figure 10) is correct (37 mbar for propane or 20 mbar for natural gas).

C2) Adjustment to reduced heat output:

- disconnect the modulator power cable and unscrew the screw (b) until a pressure value corresponding to reduced heat output is achieved (see tab. 1);
- reconnect the wire;
- mount the modulator cover and seal.

C3) Final checks

- attach the additional plate supplied with the transformer specifying the type of gas and the calibration performed;
- only for model 10 F - 18 F set parameter F08 as described in section 21.

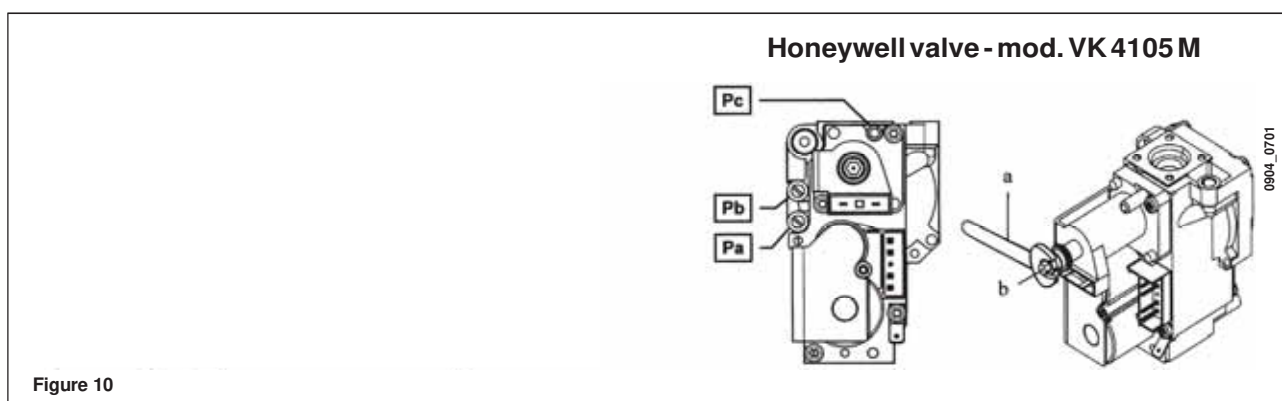

Figure 10

Table of burner injectors

	24	
gas type	G20	G31
diameter of nozzles (mm)	1,18	0,77
Burner pressure (mbar*) REDUCED HEAT OUTPUT	2,2	5,4
Burner pressure (mbar*) RATED HEAT OUTPUT	13,1	29,3
N° nozzles	13	

	1.24 F - 24 F - 18 F		10 F	
gas type	G20	G31	G20	G31
diameter of nozzles (mm)	1,35	0,85	1,35	0,85
Burner pressure (mbar*) REDUCED HEAT OUTPUT	2,2	5,4	2,4	5,6
Burner pressure (mbar*) RATED DHW HEAT OUTPUT	11,3	28,5	11,3	28,5
N° nozzles	11			

* 1 mbar = 10,197 mm H₂O

Table 1

	24	
Consumption 15°C-1013 mbar	G20	G31
Rated power	2,78 m ³ /h	2,04 kg/h
Reduced power	1,12 m ³ /h	0,82 kg/h
p.c.i.	34,02 MJ/m ³	46,34 MJ/kg

	1.24 F - 24 F		18 F		10 F	
Consumption 15°C-1013 mbar	G20	G31	G20	G31	G20	G31
DHW Rated power	2,73 m ³ /h	2,00 kg/h	2,73 m ³ /h	2,00 kg/h	2,73 m ³ /h	2,00 kg/h
CH Rated power	2,73 m³/h	2,00 kg/h	2,11 m³/h	1,55 kg/h	1,19 m³/h	0,88 kg/h
Reduced power	1,12 m ³ /h	0,82 kg/h	1,12 m ³ /h	0,82 kg/h	1,19 m ³ /h	0,88 kg/h
p.c.i.	34,02 MJ/m ³	46,34 MJ/kg	34,02 MJ/m ³	46,34 MJ/kg	34,02 MJ/m ³	46,34 MJ/kg

Table 2

20. VISUALISATION OF PARAMETERS ON THE DISPLAY (“INFO” FUNCTION)

Press “i” for at least 5 seconds to visualise certain boiler information on the display on the front panel of the boiler.

N.B.: when the “INFO” function is enabled, the message “A00”, alternating with the boiler delivery temperature, is shown on the display (figure 12):

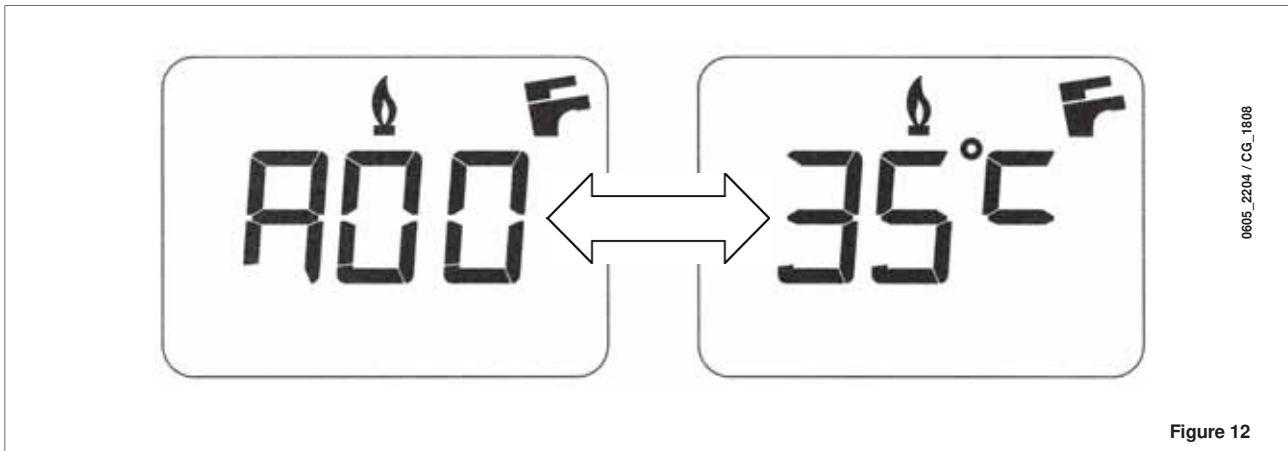



- Press buttons  (+/-) to display the following information:





- A00:** current DHW temperature (°C);
- A01:** current external temperature (°C) (with external probe connected);
- A02:** current (%) at modulator (100% = 230 mA NATURAL GAS - 100% = 310 mA LPG);
- A03:** power range (%) (MAX R);
- A04:** heating setpoint temperature (°C);
- A05:** current heating delivery temperature (°C);
- A06:** DHW temperature setpoint value (°C);
- A07:** flame signal (%) value (0-100%);
- A08:** value (l/minx10) of the DHW flow rate;
- A09:** last error that occurred in the boiler;

- This function remains active for 3 minutes. It is possible to interrupt the “INFO” function in advance by holding down the button (i) for at least 5 seconds, or turning off the power to the boiler.

21. PARAMETERS SETTING

To set the boiler parameters press the (− ) and (− ) buttons together for at least 6 seconds. When the function is active, the letters “F01” will appear on the display, alternating with the value of the parameter shown.

Changing the parameters

- Press the (+/− ) buttons to scroll through the parameters;
- Press the (+/− ) buttons to change each parameter value;
- Press the button () to save changes, the display shows “MEM”;
- Press the button () to leave the function without saving, the display shows “ESC”;

	Description of parameters	Factory settings				
		24 F	1. 24 F	24	18 F	10 F
F01	Type of boiler 10 = sealed chamber - 20 = atmospheric chamber	10	10	20	10	10
F02	Gas used 00 = NATURAL (METHANE) - 01 = LPG	00 o 01				
F03	Hydraulic system 00 = instant appliance 03 = appliance with external storage boiler 04 = appliance for heating only	00	04	00	00	00
F04/ F05	Setting programmable relays 1 and 2 (See SERVICE instructions) 00 = no associated function	00				
F06	Maximum temperature setpoint setting (°C) 00 = 85°C - 01 = 45°C	00				
F07	Configuration DHW priority input	00				
F08 (*)	Max heating power (0-100%)	100	100	100	66 (72 GPL) (*)	0
F09	Max DHW power (0-100%)	100				
F10	Min heating power (0-100%)	00				
F11	Waiting time in heating before a new ignition (00-10 minutes) - 00=10 seconds	03				
F12	Diagnostics (See SERVICE Instructions)	--				
F13	Type of exchanger 00 = 270 mm 01 = 225 mm	01	01	00	01	01
F14	Testing the correct position of the DHW probe 00 = Disable 01 = Enable	00				
F15	factory setting	00				

(*) For 18 F model the value of F08 parameter shown in the table is indicative. The value of F08 parameter has to correspond to a burner pressure, with the boiler operating at CH max heat output, as shown in the table below.

G20	G31
6,8 ± 0,3 mbar	17,2 ± 0,3 mbar

If the burner pressure, with the boiler operating at CH max heat output, is different from the specified value, change the value of F08 parameter.

22. ADJUSTMENT AND SAFETY DEVICES

This boiler has been designed in full compliance with European reference standards and, in particular, it is fitted with the following:

- **Air pressure switch (model 24 F - 1.24 F - 18 F - 10 F)**

This device only allows the burner to ignite if the exhaust flue duct is in perfect working order.

In the event of one or more of the following faults:

- flue terminal obstructed
- venturi tubes obstructed
- fan blocked
- venturi tube connection - pressure switch tripped

the boiler remains on standby and error code E03 is displayed (see table in section 10).

- **Fumes thermostat (model 24)**

This device, the sensor of which is positioned to the left of the fumes hood, interrupts the flow of gas to the main burner if the flue is obstructed and/or there is no draught.

In these conditions the boiler shuts down and displays error code E03 (section 10).

After eliminating the problem, it is possible to reignite by holding down the **(R)**, button for at least 2 seconds.

It is forbidden to disable this safety device

- **Safety thermostat**

Thanks to a sensor placed on the heating delivery line, the thermostat interrupts the flow of gas to the burner if the water in the primary circuit overheats. In these conditions, the boiler is blocked and only after the fault has been eliminated can it be ignited again by pressing **(R)**, button for at least 2 seconds.

It is forbidden to disable this safety device

- **Flame ionisation detector**

The flame sensing electrode, located on the right-hand side of the burner, guarantees safety of operation in case of gas failure or incomplete ignition of the burner.

In these conditions, the boiler is blocked after 3 ignition attempts.

Press the **(R)**, for at least 2 seconds to re-establish normal operating conditions.

- **Hydraulic pressure switch**

This device allows the main burner to be ignited only if system pressure is higher than 0.5 bars.

- **Pump overrun for heating circuit**

The electronically-controlled pump post-circulation function lasts 180 seconds and is enabled, in the heating mode, if the ambient thermostat causes the burner to go out.

- **Pump overrun for DHW circuit**

The electronically-controlled pump post-circulation function lasts 30 seconds and is enabled, in the DHW mode, if the probe causes the burner to go out.

- **Frost protection device (heating and DHW systems)**

The electronic boiler management system includes a "frost protection" function for the heating system which, when delivery temperature falls below 5°C, operates the burner until a delivery temperature of 30°C is reached. This function is enabled when the boiler is switched on, the gas supply is open and the system is correctly pressurised.

- **Water not circulating in primary circuit (pump probably blocked)**

If there is insufficient or no water circulating in the primary circuit, the boiler blocks and the error code E25 is shown on the display (section 10).

- **Anti-block pump function**

If no heat demand is received for 24 consecutive hours, in the heating mode, the pump will automatically start and operate for 10 seconds.

This function is operative when the boiler is powered.

- **Three-way valve anti-blockage function**

If no heat demand is received for a period of 24 hours, the three-way valve performs a complete switching cycle. This function is operative when the boiler is powered.

- **Hydraulic safety valve (heating circuit)**

This device is set to 3 bar and is used for the heating circuit.

Connect the safety valve to a drain tap. Do not use it to drain the heating circuit.

N.B.: domestic hot water is guaranteed even if the NTC sensor develops a fault. In this case, temperature is controlled by the delivery sensor.

23. POSITIONING THE IGNITION AND FLAME-SENSING ELECTRODE

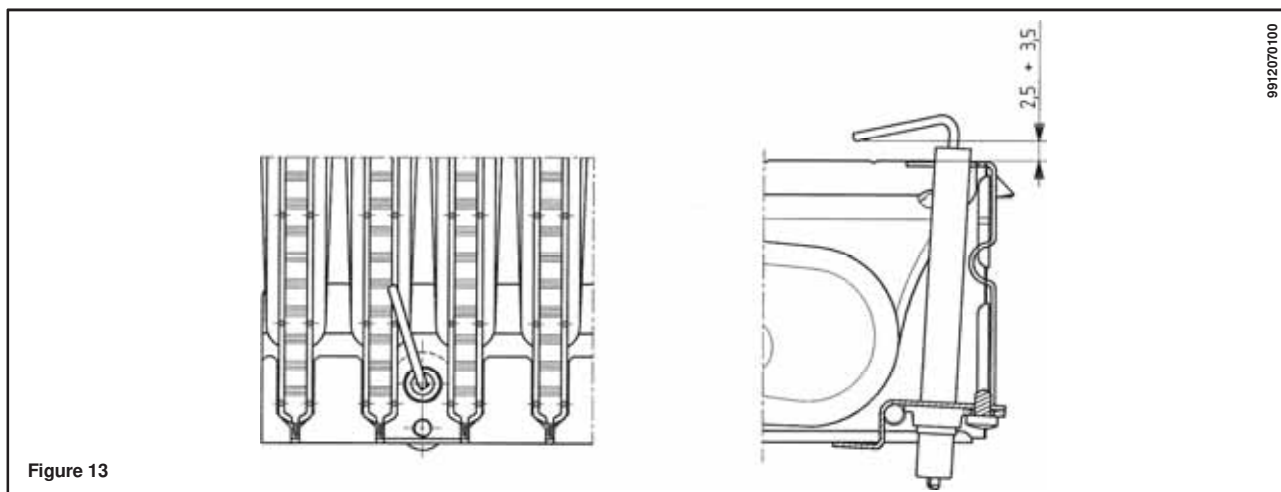

Figure 13

24. CHECKING COMBUSTION PARAMETERS

To measure combustion efficiency and the toxicity of the products of combustion, the boiler is fitted with two dedicated test points.

One test point is connected to the exhaust duct and is used to measure combustion efficiency and the toxicity of the products of combustion.

The other is connected to the air intake duct and is used to check for the presence of any products of combustion circulating in installations with co-axial flues.

The following parameters can be measured using the test point connected to the exhaust duct:

- temperature of the products of combustion;
- concentration of oxygen (O_2) or, alternatively, carbon dioxide (CO_2);
- concentration of carbon monoxide (CO).

The temperature of the comburent air must be measured on the test point located on the air intake flue by inserting the measurement sensor by about 3 cm.

N.B.: to regulate the rated power, see chapter 19 (C1)

For natural draught boiler models, a hole must be made in the exhaust duct at a distance from the boiler equal to twice the internal diameter of the flue. The following parameters can be measured inside this hole:

- temperature of the products of combustion;
- concentration of oxygen (O_2)
- concentration of carbon monoxide (CO).

The temperature of the combustion air must be measured close to the point where the air enters the boiler.

The hole, which must be made by the person in charge of the system during commissioning, must be sealed so as to ensure that the exhaust duct is airtight during normal operation.

25. PUMP CAPACITY/ HEAD

A high static head pump, suitable for installation on any type of single- or double-pipe heating system, is used. The automatic air valve incorporated in the pump allows quick venting of the heating system.

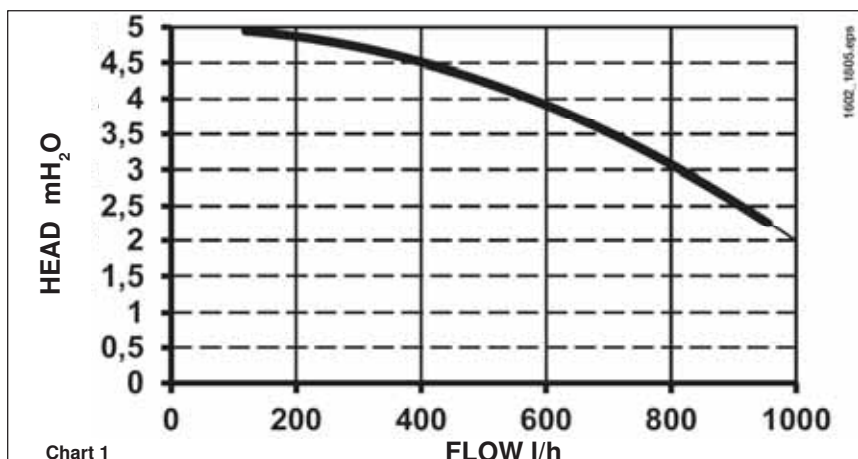

26. CONNECTING THE EXTERNAL PROBE

The wiring harness leaving the control board includes two RED wires fitted with faston covers. Connect the external probe to these two wires.

With the external probe connected it is possible to change the curve "kt" (Graph 1) by means of the +/- IIIII buttons.

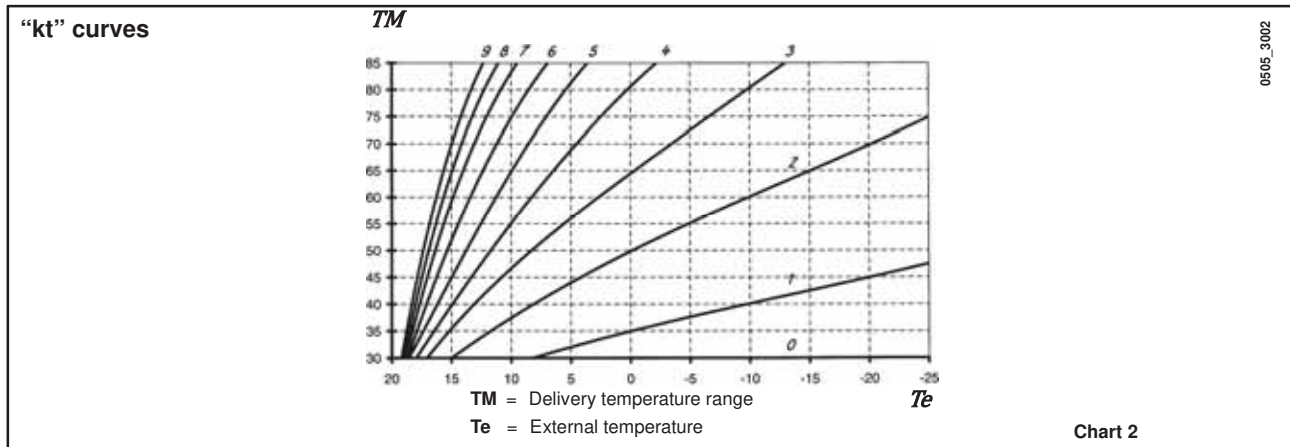

27. CONNECTION OF AN EXTERNAL STORAGE BOILER

Model 1.24 F

The DHW priority sensor NTC and the motor of the 3-way valve are not included in the kit of the appliance because they are supplied as accessories.

STORAGE BOILER PROBE CONNECTION

The boiler may be connected to an external storage boiler. Hydraulically connect the storage boiler as in fig. 14. Connect the DHW priority sensor NTC to the terminals 5-6 on the terminal block M2. The sensitive element of the sensor NTC must be inserted in the special well provided on the storage boiler. The DHW temperature (35 °C...60 °C) is regulated by means of the +/- IIIII buttons.

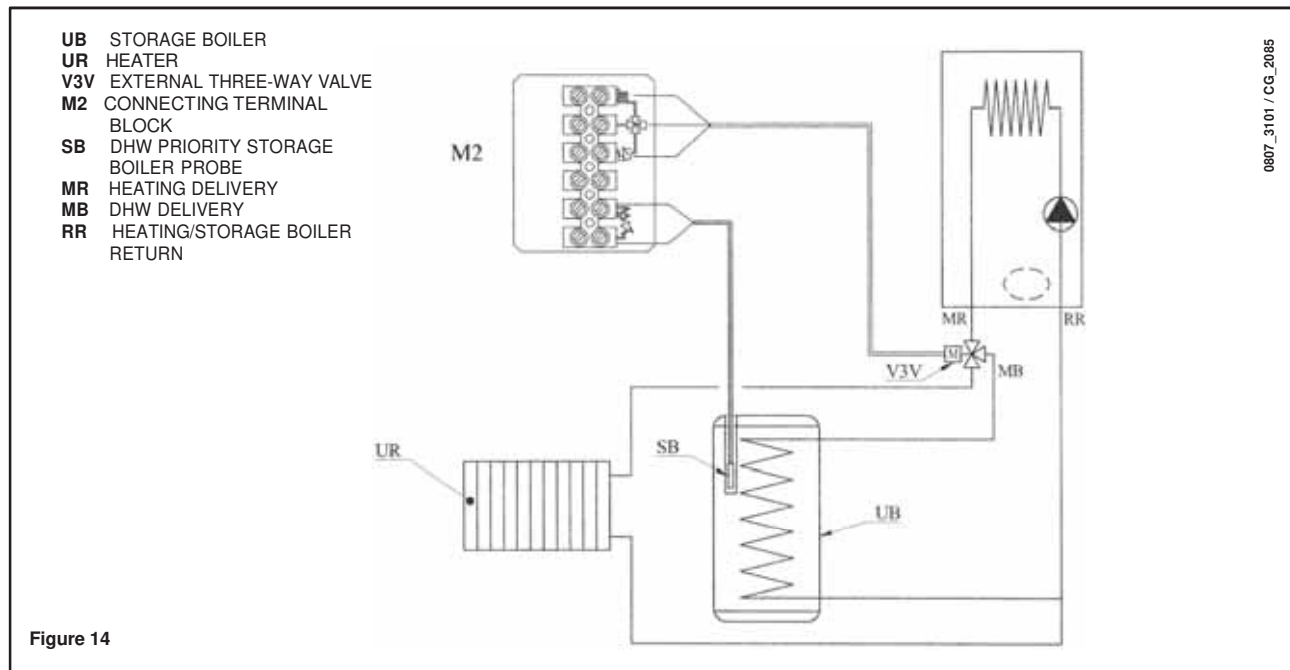

IMPORTANT: Ensure that parameter **F03 = 03** (section 21).

ELECTRICAL CONNECTION OF THE 3-WAY VALVE MOTOR (models 1.24 F)

The motor of the 3-way valve and the respective wiring are supplied separately as a kit. Connect the motor of the 3-way valve as described in the instructions supplied with the accessory.

28. NOTES FOR INSTALLATIONS WITH SEPARATE OUTLETS

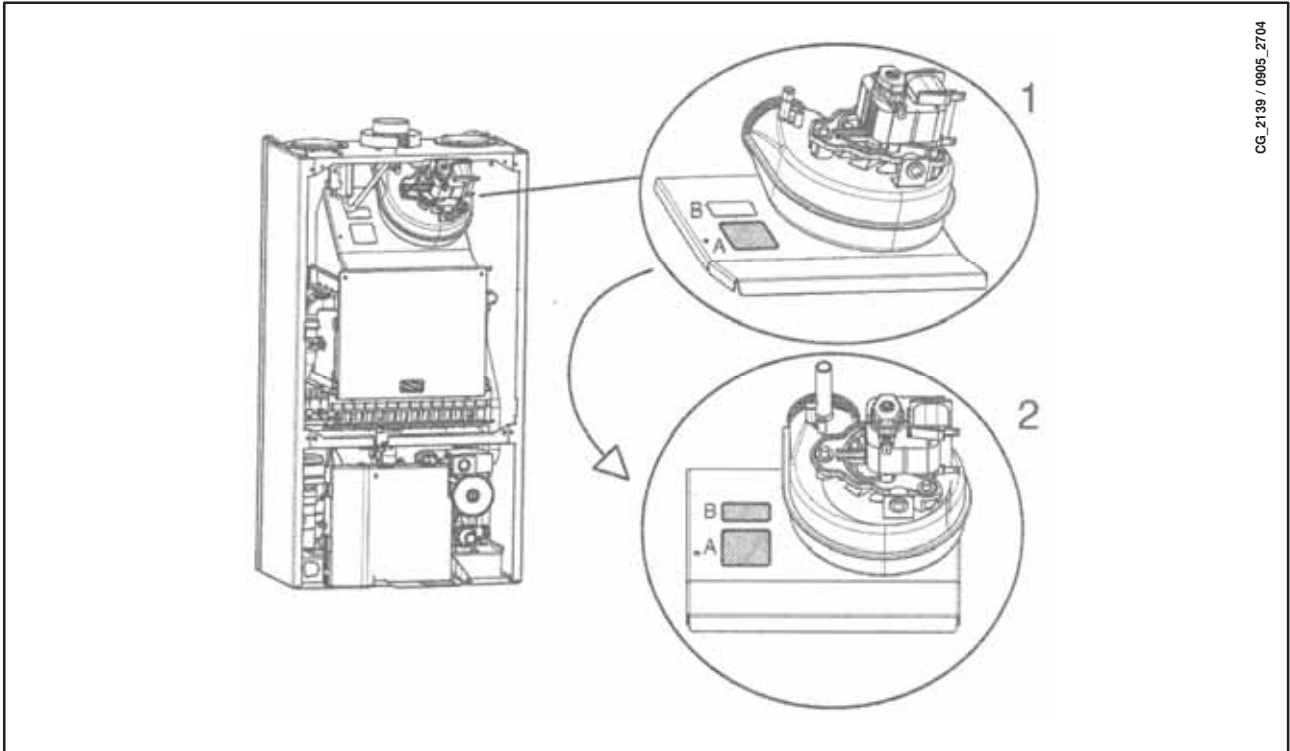

In special cases, installations with separate outlets can generate vibrations that may cause the fumes pressure switch to trip (fault E03 on the boiler display).

To solve this problems, two slots closed with pre-punched holes (Ref. **A** and **B**) have been prepared on the fumes outlet. These can be easily removed by the Qualified Technical Assistance Service without having to remove the outlet.

Remove knock-out **A** (Detail **1**) and check the appliance works correctly.
If not, remove knock-out **B** (Detail **2**) as well.

29. ANNUAL SERVICING

To optimise boiler efficiency, carry out the following annual controls:

- check the appearance and air-tightness of the gaskets of the gas and combustion circuits;
- check the state and correct position of the ignition and flame-sensing electrodes;
- check the state of the burner and make sure it is firmly fixed;
- check for any impurities inside the combustion chamber.
Use a vacuum cleaner to do this;
- check the gas valve is correctly calibrated;
- check the pressure of the heating system;
- check the pressure of the expansion vessel;
- check the fan works correctly;
- make sure the flue and air ducts are unobstructed;

WARNINGS

Before commencing any maintenance operations, make sure the boiler is disconnected from the power supply. Afterwards, move the knobs and/or operating parameters of the boiler to their original positions.

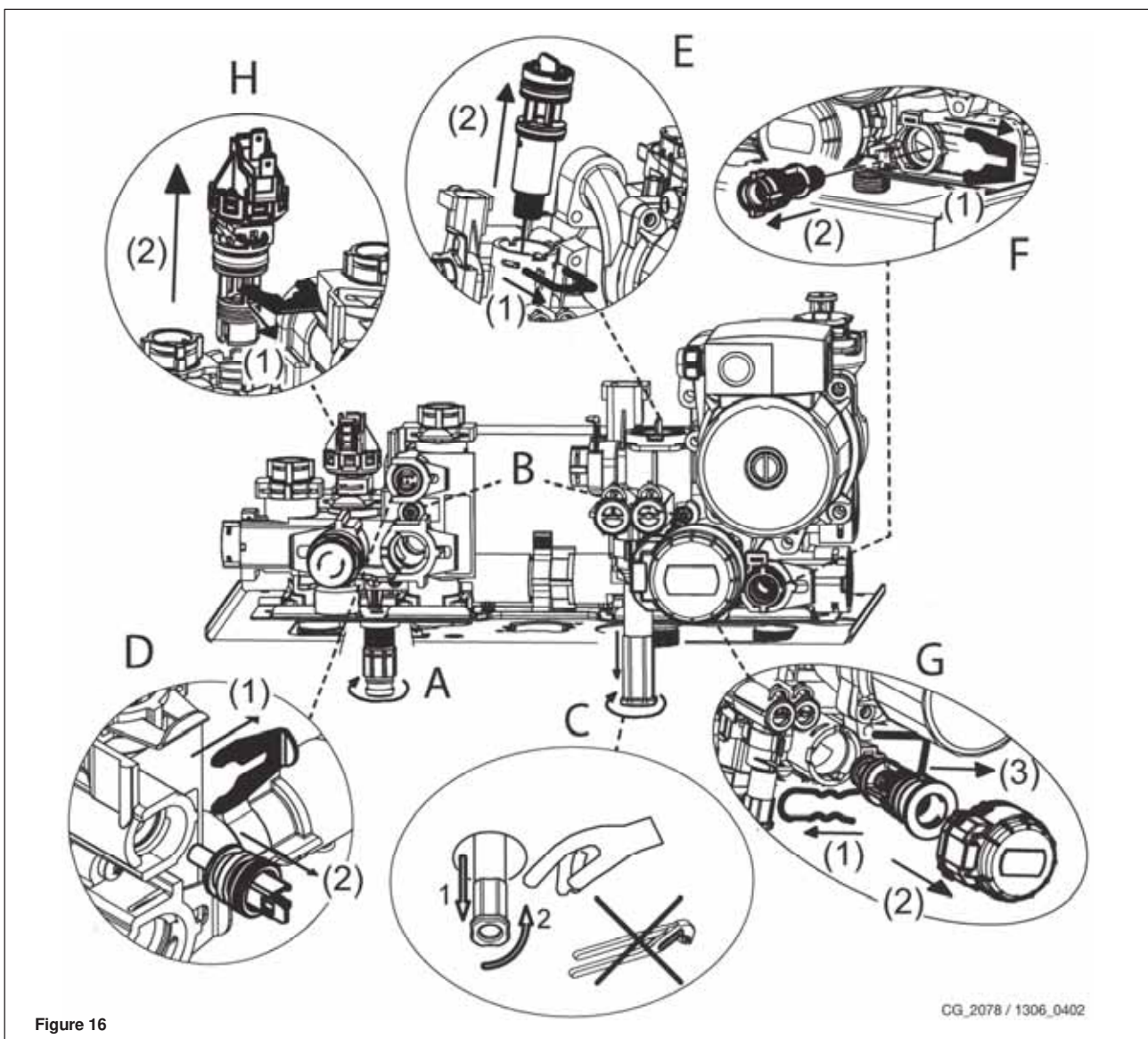

WARNING

Pay great attention when dismantling the individual parts of the hydraulic assembly. Do not use sharp tools, do not apply excessive force when removing the fixing clip.

30. CLEANING THE FILTERS

The DHW filters and the filters of the heating circuit are housed in special extractable cartridges. The cartridge of the heating circuit is located on the return of the heating (figure 16F), the cartridge of the DHW circuit is on the cold water input (figure 16E). To clean the filters, proceed as described below:

- turn off the electric power supply to the boiler;
- turn off the DHW inlet tap
- drain the water out of the heating circuit, turning on tap A in figure 16.
- remove the clip (1-E/F) from the filter as illustrated in the figure and take out the cartridge (2-E/F) containing the filter, taking care not to apply excessive force;
- to extract the cartridge of the heating filter you must first remove the motor of the 3-way valve (1-2G - figure 16);
- eliminate any impurities and deposits from the filter;
- reposition the filter in the cartridge and put it back into its housing, securing it with the clip.
- to change the DHW NTC sensor, see figure 16D.

IMPORTANT

when replacing and/or cleaning the O-rings on the hydraulic assembly, only use Molykote 111 as a lubricant, not oil or grease.

31. REMOVING SCALE FROM THE DHW CIRCUIT

The DHW circuit can be cleaned without removing the water-water heat exchanger if the assembly is fitted with the special tap (available on request) located on the DHW outlet.

To clean, proceed as follows:

- Turn off the DHW inlet tap
- Drain the DHW system by opening a hot water tap
- Turn off the DHW outlet tap
- Remove the clip 1E in figure 16
- Remove the filter (2E fig 16).

If the special tap is not supplied, dismantle the water-water heat exchanger, as described in the next section, and clean it separately. Remove the scale from the seat and relative NTC sensor fitted on the DHW circuit (figure 16D).

To clean the exchanger and/or DHW circuit, use Cillit FFW-AL or Benckiser HF-AL.

32. DISMOUNTING THE WATER-WATER HEAT EXCHANGER

The stainless steel plate-type water-water heat exchanger is easily disassembled with a screwdriver by operating as described below:

- drain the system, just the boiler if possible, through the drain tap;
- drain the DHW system;
- remove the two screws at the front securing the water-water heat exchanger and pull it out (figure 16B).

33. FUNCTIONAL CIRCUIT DIAGRAM

10 F - 18 F - 24 F

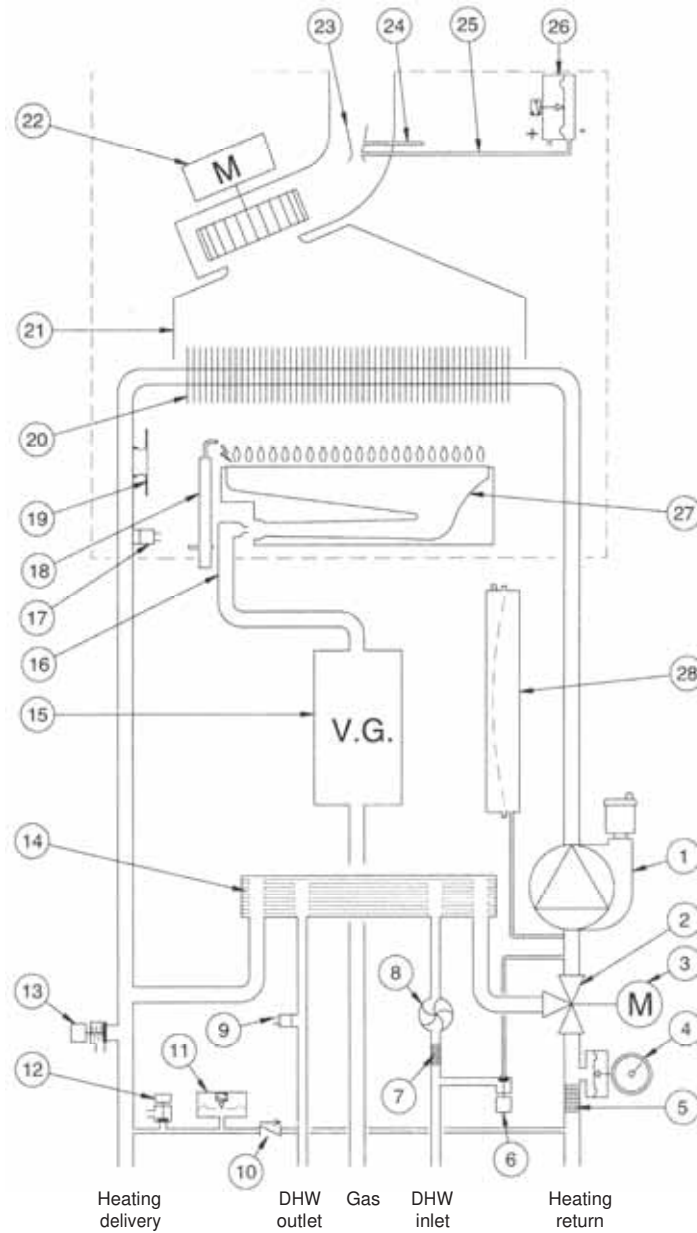

CG_2082 / 1001_1802

Figure 17

Legend:

- | | |
|--------------------------------------|---|
| 1 Pump and air separator | 15 Gas valve |
| 2 Three-way valve | 16 Gas train with injectors |
| 3 Three-way valve motor | 17 Central heating NTC sensor |
| 4 Pressure gauge | 18 Ignition / flame detection electrode |
| 5 Heating circuit extractable filter | 19 Safety thermostat |
| 6 Boiler filling tap | 20 Water-fumes exchanger |
| 7 Cold water extractable filter | 21 Fumes conveyor |
| 8 DHW priority sensor | 22 Fan |
| 9 NTC domestic hot water sensor | 23 Venturi tube |
| 10 Check valve on automatic by-pass | 24 Positive pressure point |
| 11 Water pressure switch | 25 Negative pressure point |
| 12 Boiler drain tap | 26 Air pressure switch |
| 13 Safety valve | 27 Burner |
| 14 Water-water plate heat exchanger | 28 Expansion vessel |

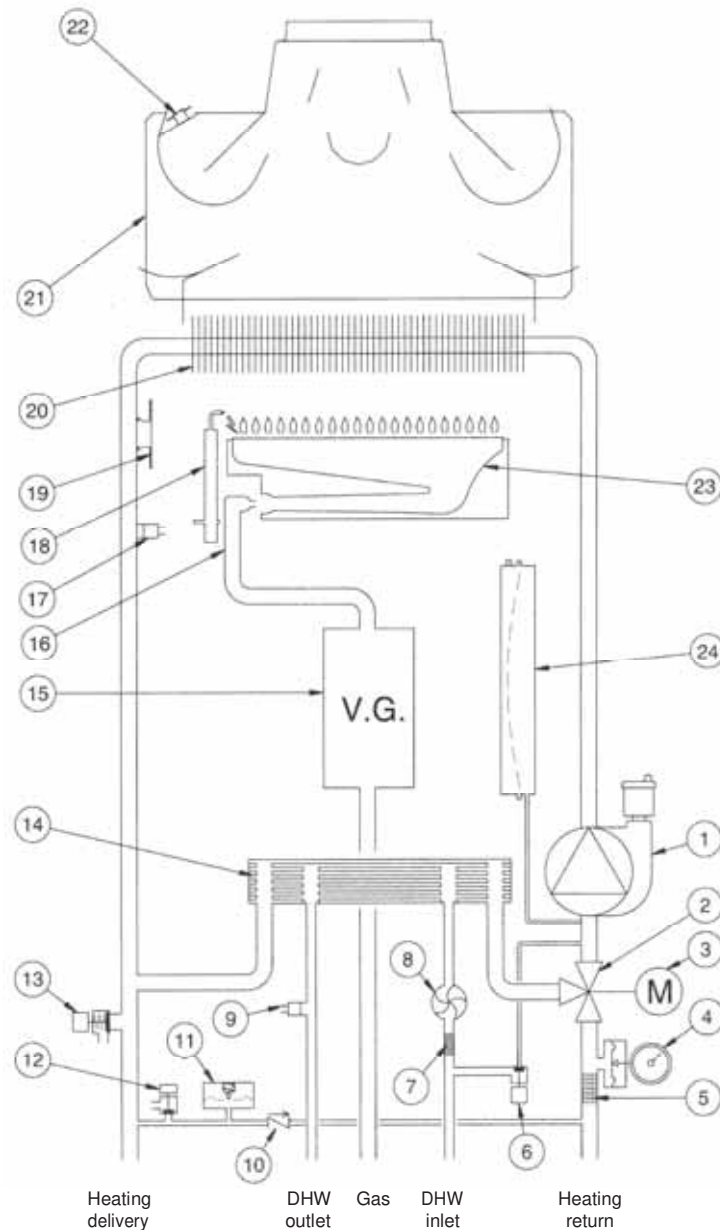
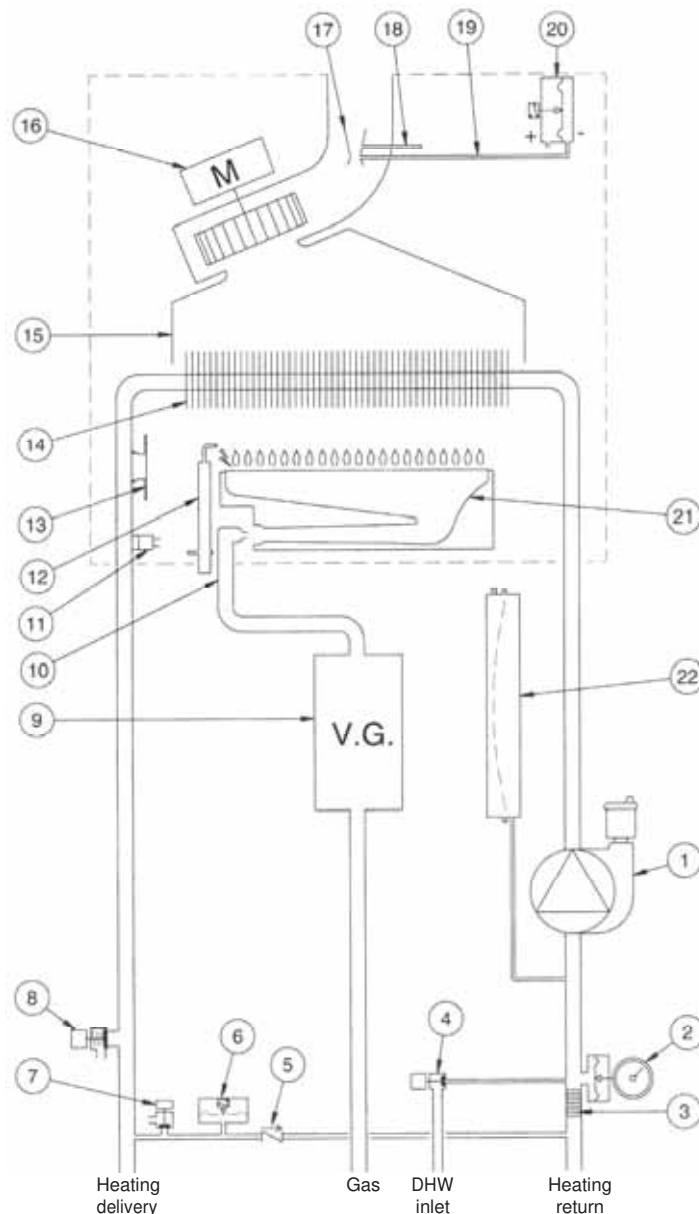

Figure 18

Legend:

- | | |
|--------------------------------------|---|
| 1 Pump and air separator | 13 Safety valve |
| 2 Three-way valve | 14 Water-water plate heat exchanger |
| 3 Three-way valve motor | 15 Gas valve |
| 4 Pressure gauge | 16 Gas train with injectors |
| 5 Heating circuit extractable filter | 17 Central heating NTC sensor |
| 6 Boiler filling tap | 18 Ignition / flame detection electrode |
| 7 Cold water extractable filter | 19 Safety thermostat |
| 8 DHW priority sensor | 20 Water-fumes exchanger |
| 9 NTC domestic hot water sensor | 21 Fumes conveyor |
| 10 Check valve on automatic by-pass | 22 Fumes thermostat |
| 11 Water pressure switch | 23 Burner |
| 12 Boiler drain tap | 24 Expansion vessel |

1.24 F



CG_2084 / 1001_1804

Figure 19

Legend:

- | | |
|--------------------------------------|---|
| 1 Pump and air separator | 12 Ignition / flame detection electrode |
| 2 Pressure gauge | 13 Safety thermostat |
| 3 Heating circuit extractable filter | 14 Water-fumes exchanger |
| 4 Boiler filling tap | 15 Fumes conveyor |
| 5 Check valve on automatic by-pass | 16 Fan |
| 6 Water pressure switch | 17 Venturi tube |
| 7 Boiler drain tap | 18 Positive pressure point |
| 8 Safety valve | 19 Negative pressure point |
| 9 Gas valve | 20 Air pressure switch |
| 10 Gas train with injectors | 21 Burner |
| 11 Central heating NTC sensor | 22 Expansion vessel |

34. WIRING DIAGRAM

10 F - 18 F - 24 F

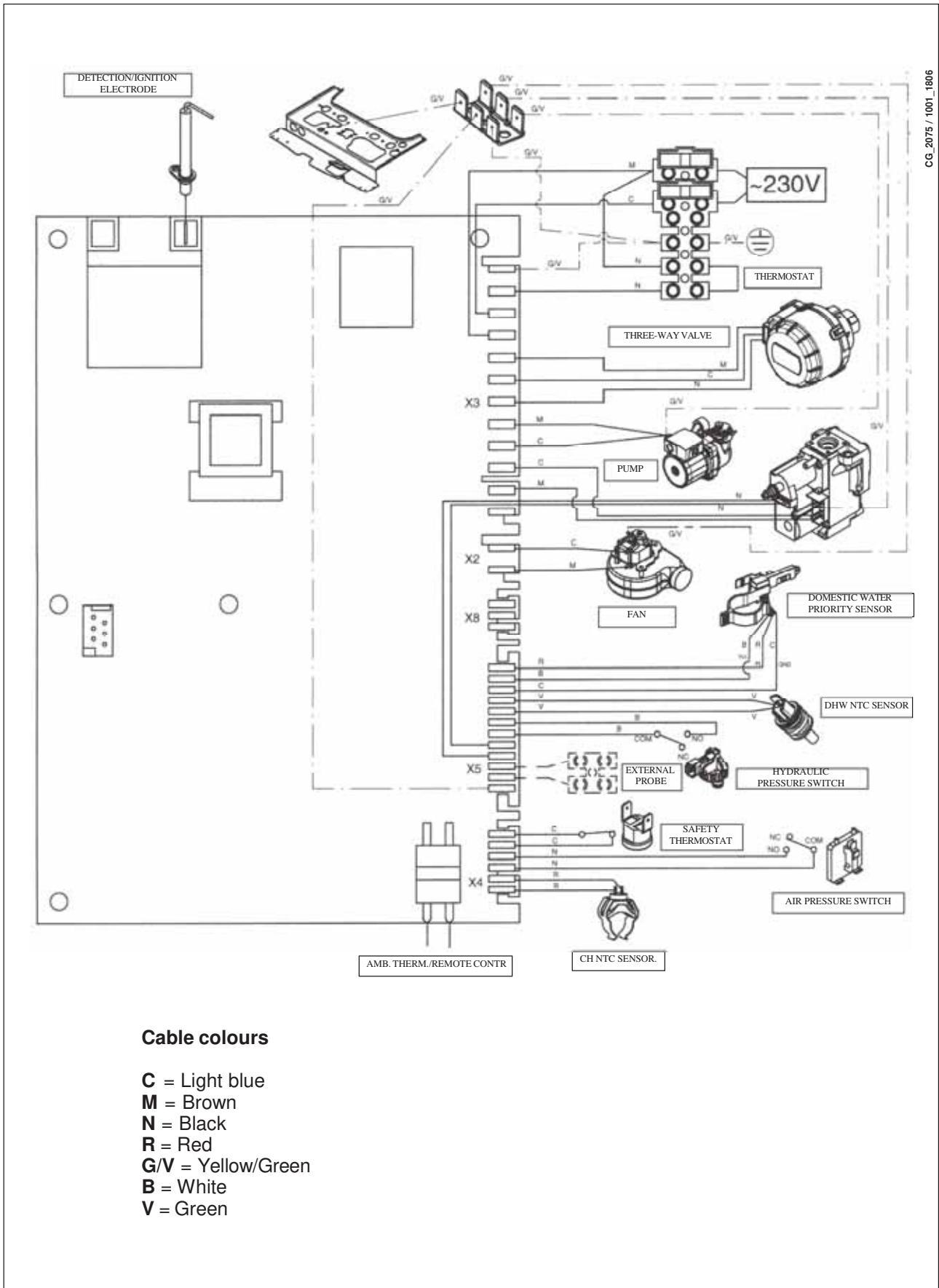

CG_2075 / 1001_1806

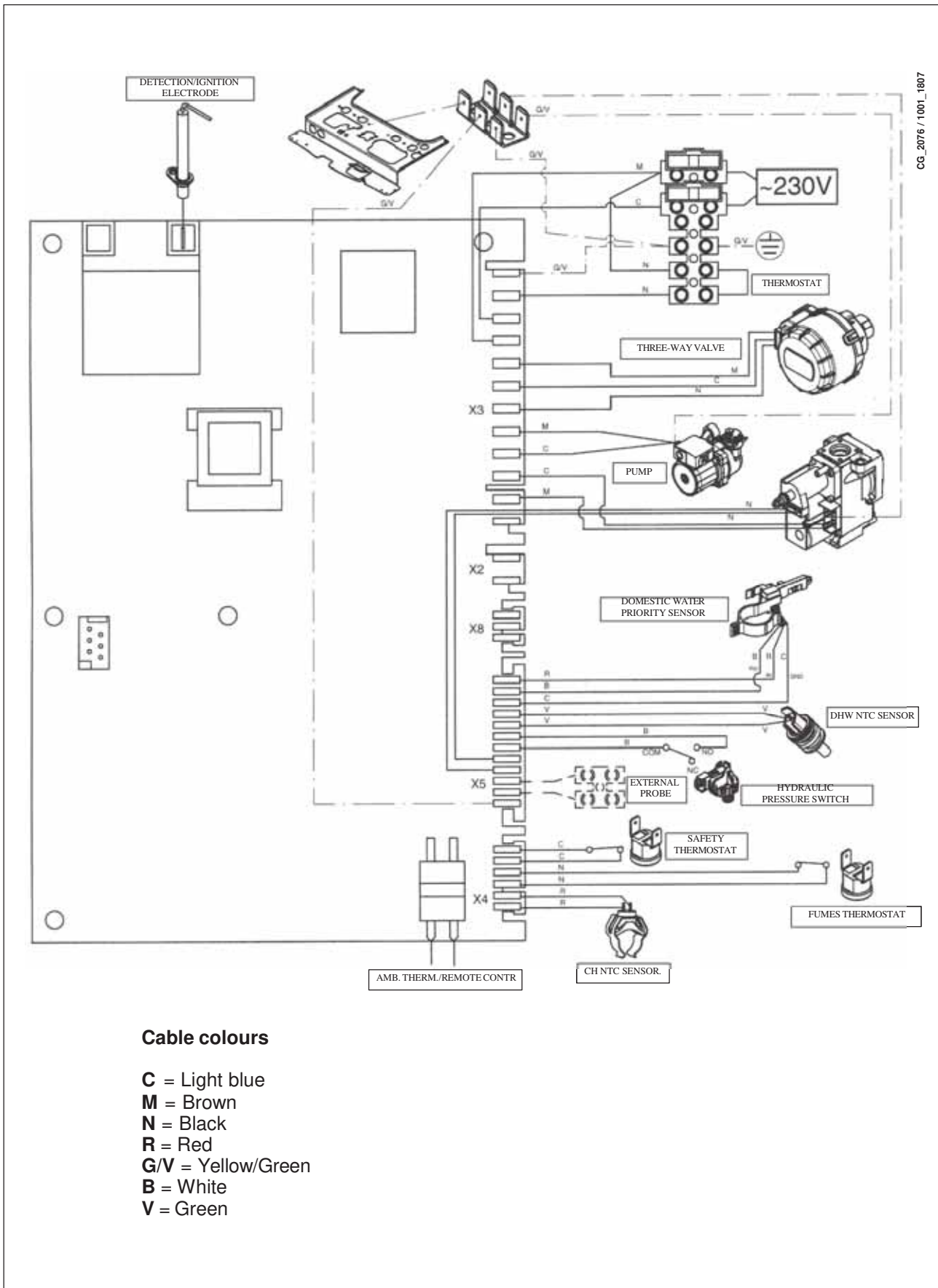

1.24 F

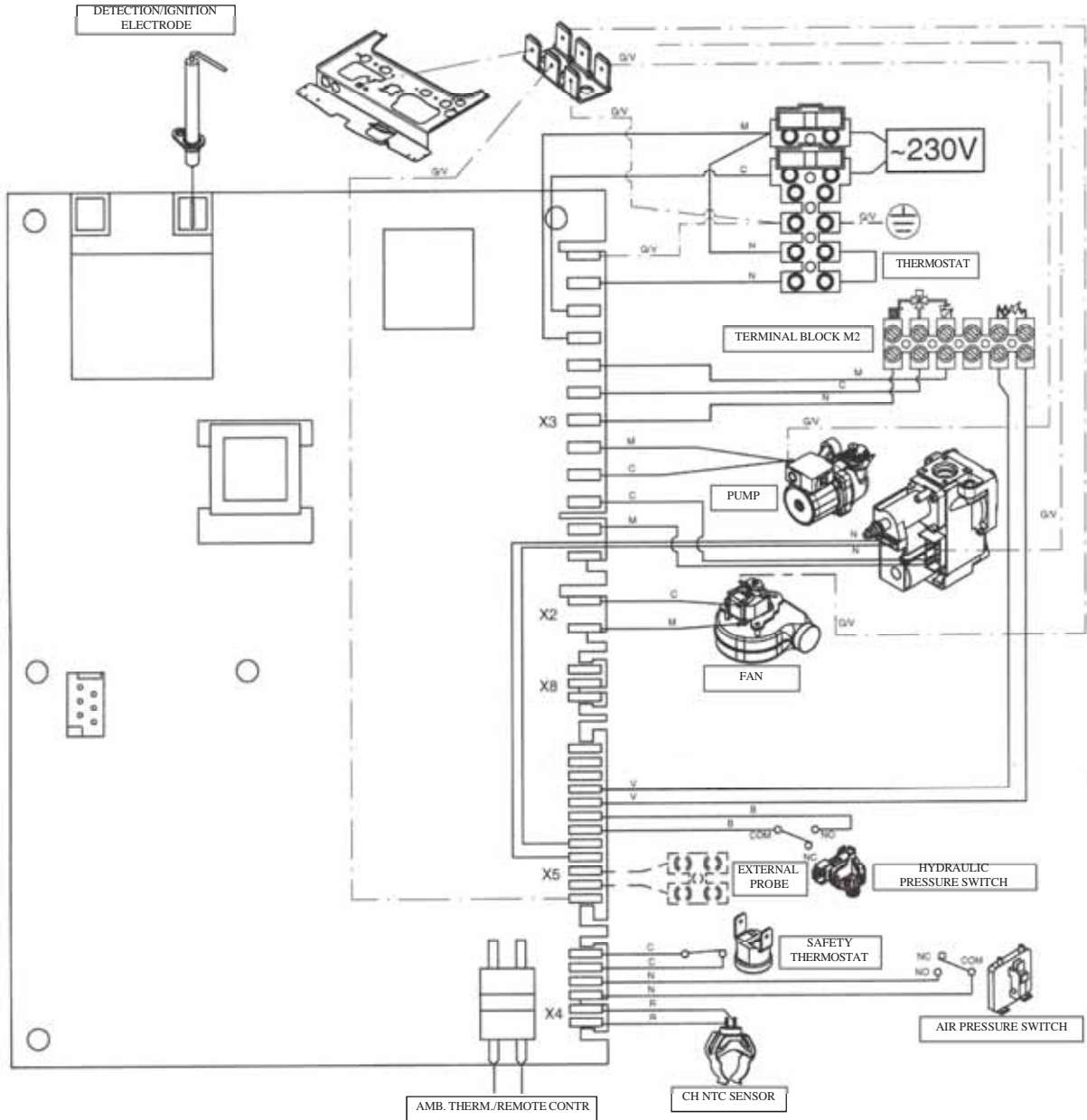

CG_2086 / 1001_1808

Cable colours

- C** = Light blue
- M** = Brown
- N** = Black
- R** = Red
- G/V** = Yellow/Green
- B** = White
- V** = Green

35. TECHNICAL DATA

Model ECO4s		24 F	1.24 F	18 F	10 F	24
Category		II _{2H3P}	II _{2H3P}	II _{2H3P}	II _{2H3P}	II _{2H3P}
Rated heat input (DHW)	kW	25,8	-	25,8	25,8	26,3
Rated heat input (CH)	kW	25,8	25,8	20	11,3	26,3
Reduced heat input	kW	10,6	10,6	10,6	11,3	10,6
Rated heat output (DHW)	kW	24	-	24	24	24
	kcal/h	20.600	-	20.600	20.600	20.600
Rated heat output (CH)	kW	24	24	18	10	24
	kcal/h	20.600	20.600	15.480	8.600	20.600
Reduced heat output	kW	9,3	9,3	9,3	10	9,3
	kcal/h	8.000	8.000	8.000	8.600	8.000
Max. pressure in central heating system	bar	3	3	3	3	3
Capacity of expansion vessel	l	6	6	6	6	6
Pressure of expansion vessel	bar	0,5	0,5	0,5	0,5	0,5
Max. pressure in DHW system	bar	8	—	8	8	8
Minimum dynamic pressure in DHW system	bar	0,15	—	0,15	0,15	0,15
Minimum DHW output	l/min	2,0	—	2,0	2,0	2,0
DHW output at $\Delta T=25\text{ }^{\circ}\text{C}$	l/min	13,7	—	13,7	13,7	13,7
DHW output at $\Delta T=35\text{ }^{\circ}\text{C}$	l/min	9,8	—	9,8	9,8	9,8
Specific output	l/min	11	—	11	11	10,7
Temperature range in heating system	$^{\circ}\text{C}$	30/85	30/85	30/85	30/85	30/85
Temperature range in DHW system	$^{\circ}\text{C}$	35/60	—	35/60	35/60	35/60
Type	—	C12 - C32 - C42 - C52 - C82 - B22				B _{11BS}
Diameter of concentric flue duct	mm	60	60	60	60	—
Diameter of concentric air duct	mm	100	100	100	100	—
Diameter of 2-pipe flue duct	mm	80	80	80	80	—
Diameter of 2-pipe air duct	mm	80	80	80	80	—
Diameter of flue duct	mm	-	-	-	-	120
Max. mass flow of fumes	kg/s	0,016	0,016	0,016	0,016	0,020
Min. mass flow of fumes	kg/s	0,016	0,016	0,016	0,016	0,018
Max. temperature of fumes	$^{\circ}\text{C}$	141	141	141	141	110
Min. temperature of fumes	$^{\circ}\text{C}$	118	118	118	118	85
NOx class	—	3	3	3	3	3
Type of gas	—	G20	G20	G20	G20	G20
	—	G31	G31	G31	G31	G31
Natural gas supply pressure	mbar	20	20	20	20	20
Propane gas supply pressure	mbar	37	37	37	37	37
Power supply voltage	V	230	230	230	230	230
Input frequency	Hz	50	50	50	50	50
Rated electrical input	W	130	130	130	130	80
Net weight	kg	30	29,5	30	30	29
Dimensions	height	mm	730	730	730	730
	width	mm	400	400	400	400
	depth	mm	299	299	299	299
Protection against humidity and water penetration (**)		IP X5D	IP X5D	IP X5D	IP X5D	IP X5D

(**) according to EN 60529

BAXI S.p.A.

36061 BASSANO DEL GRAPPA (VI) ITALIA

Via Trozzetti, 20

Servizio clienti: Tel. 0424 - 517800 - Telefax 0424/38089

www.baxi.it

Ed. 1 - 10/15

Cod. 7222863.02